



2025 Regional Meetings Tabletop Tradeshow Rules & Display Reference Guidelines

The following Exhibitor Rules & Display Reference Guidelines have been established by BWH Hotels Show Management. These guidelines are created to promote continuity and consistency among tabletop exhibitors and follow industry tabletop exhibitor standards.

Exhibitor Rules:

- Display materials should be arranged in such a manner so as not to obstruct sight lines of neighboring exhibitors.
- Floor standing banners are **not permitted** in front or on the side of the tabletop. **Any pull-up banner MUST be placed behind your table.** There will be approximately three (3) feet behind the table which includes the space needed and room for your provided chairs.
- Exhibitors are encouraged to display promotional items on the tabletop. Table display banners must not exceed five (5) feet in height and four (4) feet in width and/or floor standing display banner stands (*behind your table*) must not exceed eight (8) feet in height and six (6) feet in width.
- Exhibitors may not solicit in the aisles or in any other location in, around or outside the hotel/venue except at their tabletop booth.
- Exhibitors may be asked to remove any display items not in compliance with these guidelines.
- Storage will **not** be provided. Please place any items under your skirted table display.
- No tapes, adhesives, or any items are to be used to hang or attach signs or display materials to the hotel facility walls.

Tabletop Package Includes:

- (1) 6' x 30" Skirted Table
- (2) Chairs
- Wireless Internet Access (hard wire internet available if requested during the application process)
- (1) Standard electric drop if requested during the application process.

Shipping Information:

- Please refer to the shipping information provided on your Exhibitor portal.

Tabletop Assignment Policy:

- Space is assigned at the sole discretion of BWH Hotels Show Management. We will use reasonable efforts to provide physical separation among booths when requested by an Exhibitor to do so. Show Management reserves the right to change exhibit space assignments at any time, as BWH Hotels may, in its sole discretion, deem necessary.

QUESTIONS?

Contact: BWH Hotels Meetings & Events – bwconferences@bwh.com

Renderings for Example Only

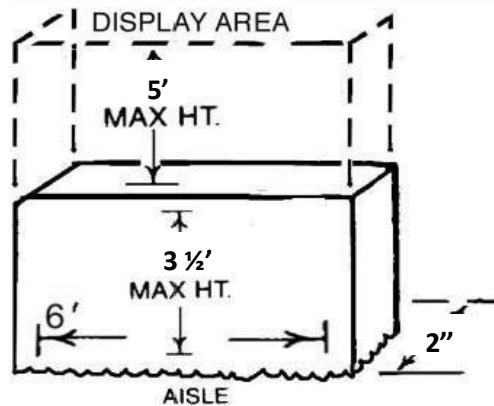

Permitted Examples:



Floor standing display banner stands (behind your table) must not exceed eight (8) feet in height and six (6) feet in width.

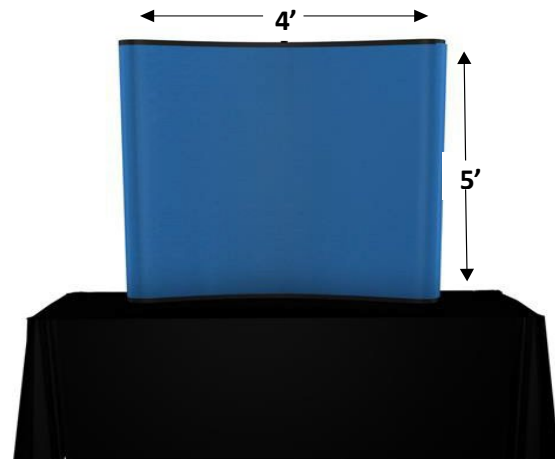
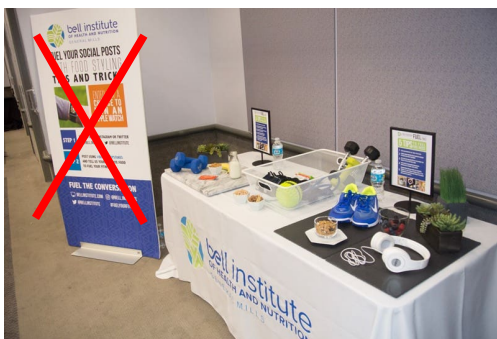

Table display banners must not exceed five (5) feet in height and four (4) feet in width.

Not Permitted:

Pull up banners must be placed either on the table top (max. 5' h) or behind your table (max 8'h x 6' wide).



Floor standing banners are **not permitted** in front or on the side of the tabletop. **Any pull-up banners MUST be placed behind your table.**