



# Forecasting surface solar irradiance with Machine Learning and EarthCARE satellite Data



Meriem Kacimi<sup>1</sup>, Howard Barker<sup>1</sup>, Jason Cole<sup>1</sup>, Zhipeng Qu<sup>1</sup>, Nicolas Clerbaux<sup>2</sup>, Almudena Velázquez Blázquez<sup>2</sup>

<sup>1</sup>: Environment and Climate Change Canada, Toronto, Ontario, Canada

<sup>2</sup>: Royal Meteorological Institute of Belgium, Brussels, Belgium

EUROPEAN SPACE AGENCY



Environment and Climate Change Canada

Meriem.Kacimi@ec.gc.ca

**Background & Motivation :** Surface Solar Irradiance (SSI) is a key variable for numerical weather prediction, climate studies, and solar energy applications. Estimation of SSI and surface radiative fluxes is traditionally performed using radiative transfer models (RTMs). These methods provide accurate and physically consistent solutions but are computationally expensive.

Artificial Intelligence / Machine Learning (AI/ML) enables data-driven estimation of surface radiative fluxes by learning complex relationships between radiance observations and surface fluxes. AI/ML methods can produce fast predictions while maintaining accuracy, thereby making them attractive for large-scale applications.

## Objectives

- Develop an AI/ML model to estimate SSI (i.e., fluxes) from satellite radiance observations.
- Train separate all-sky models for ocean and land using 3D RTM results from EarthCARE data (Sep 2024–Aug 2025).
- Verify the AI/ML model against CERES SSF SSI reference data.
- Compare its performance against a Gaussian-Legendre Quadrature method in terms of accuracy and computational speed.
- Demonstrate that it provides fast, scalable estimates with satisfactory accuracy.

## Methods

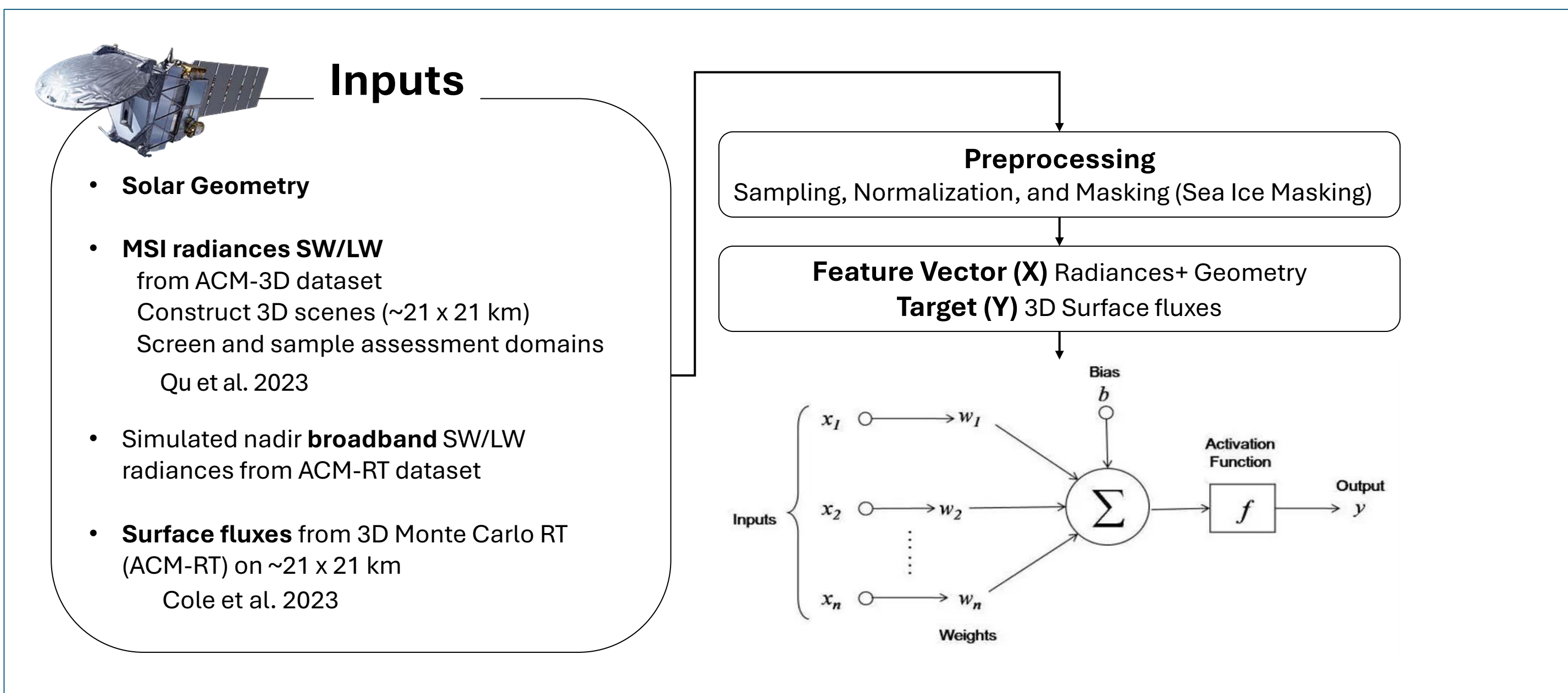

## Results (AI/ML model)

- AI/ML model evaluated over ocean and land surfaces using ACM-RT and CERES-SSF broadband SW/LW radiances.
- ACM-RT and CERES-SSF observations were collocated in time and space, with CERES data selected within 10 km of the domain center and VZA < 5° (near-nadir).
- Common MSI TOA radiances and solar geometries were used for both tests.
- Predicted surface fluxes were compared with corresponding ACM-RT simulated fluxes and CERES-SSF surface flux products.

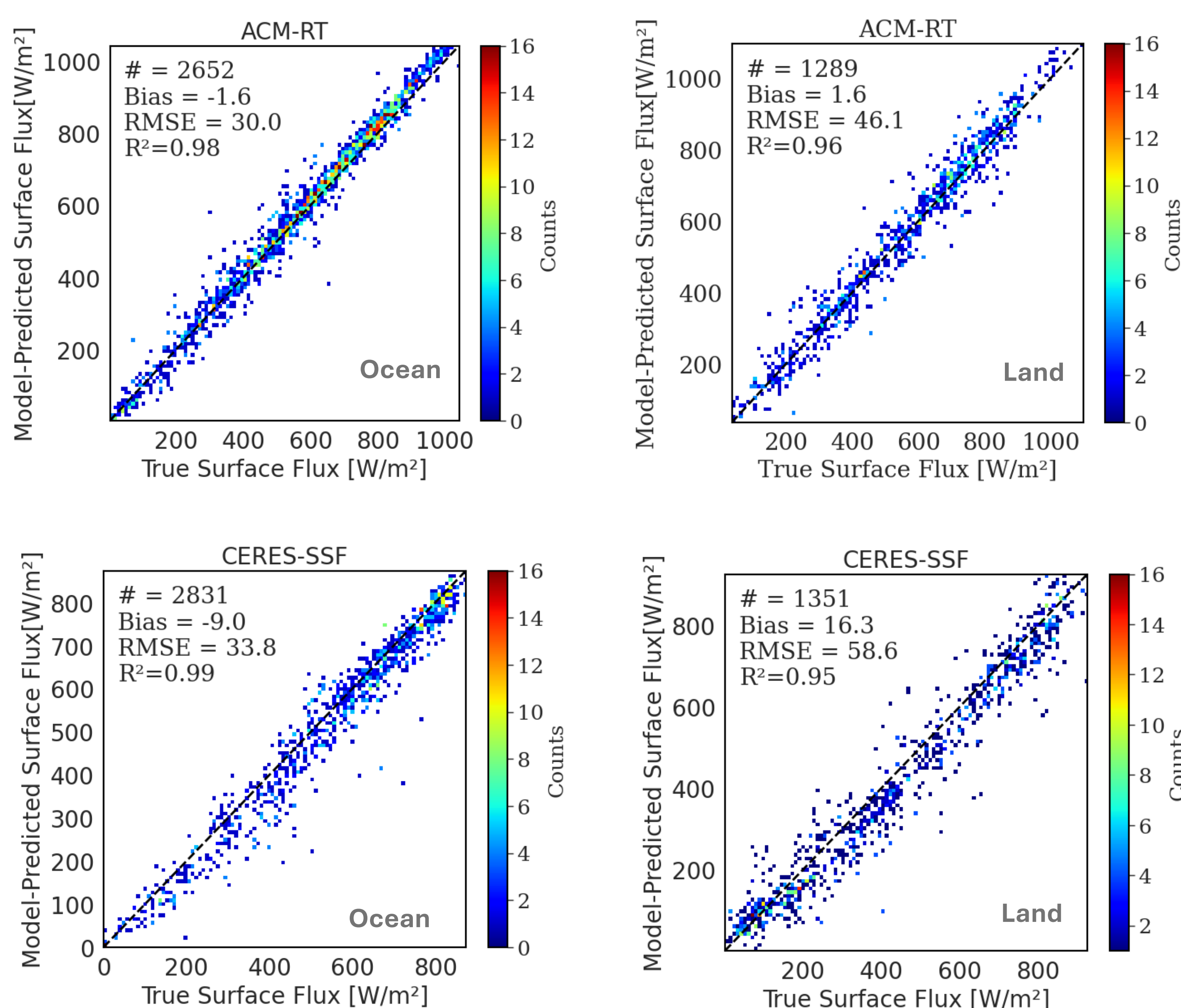

- **AI/ML using ACM-RT radiances :** good agreement between true and predicted SSI.
- **AI/ML using CERES-SSF radiances :** performance reduced relative to use of ACM-RT... increased bias and larger dispersion.

## Gauss-Legendre Quadrature (GLQ) method v. AI/ML model

- Mean SSI was computed by GLQ using sorted TOA 1D solar flux (e.g., Barker et al. *Q. J. R. Meteorol. Soc.*, 2021; **147**:1801–1822).
- GLQ was first applied with 10 quadrature points for cloudy pixels.
- Cloudy pixels were defined as those having cloud optical thickness (COT), from ACM-CAP, greater than 0.01.
- The dataset consists of 13 repeating frames sampled between October 2024 and August 2025.
- The goal is to determine the number of GLQ points required to match the accuracy of the AI/ML model for four ranges of total cloud fraction.
- For clear-sky conditions, one quadrature point is used to estimate the mean clear-sky SSI.

### Clear-Sky Quadrature point = 1

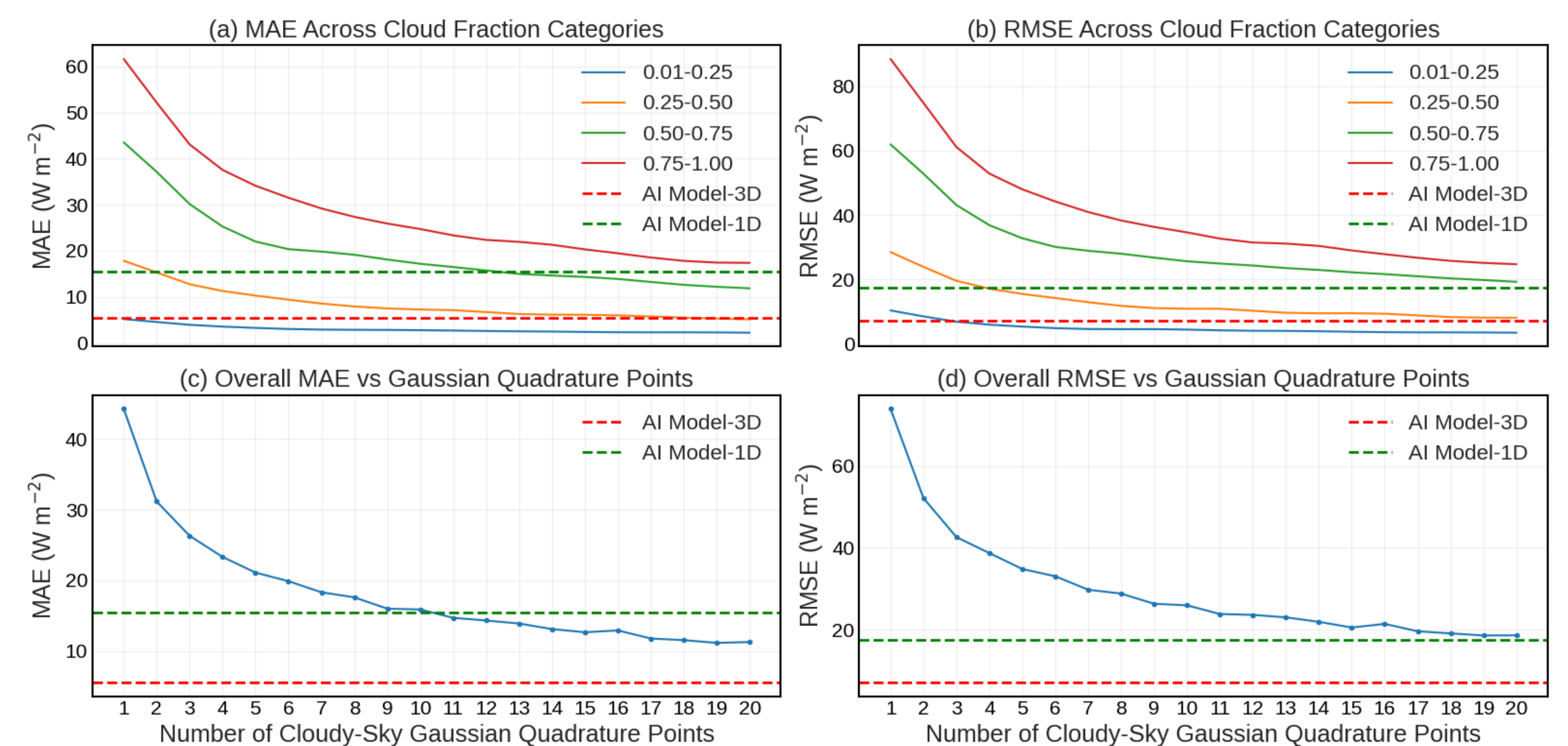

- Large cloud fractions require more quadrature points; clear and small cloud fraction cases converge quickly.
- GLQ accuracies do not improve much beyond use of ~8 - 10 quadrature points.
- Overall, AI/ML model outperforms the GLQ method in terms of accuracy and time.

### QP Configuration: 8 Cloud / 1 Clear

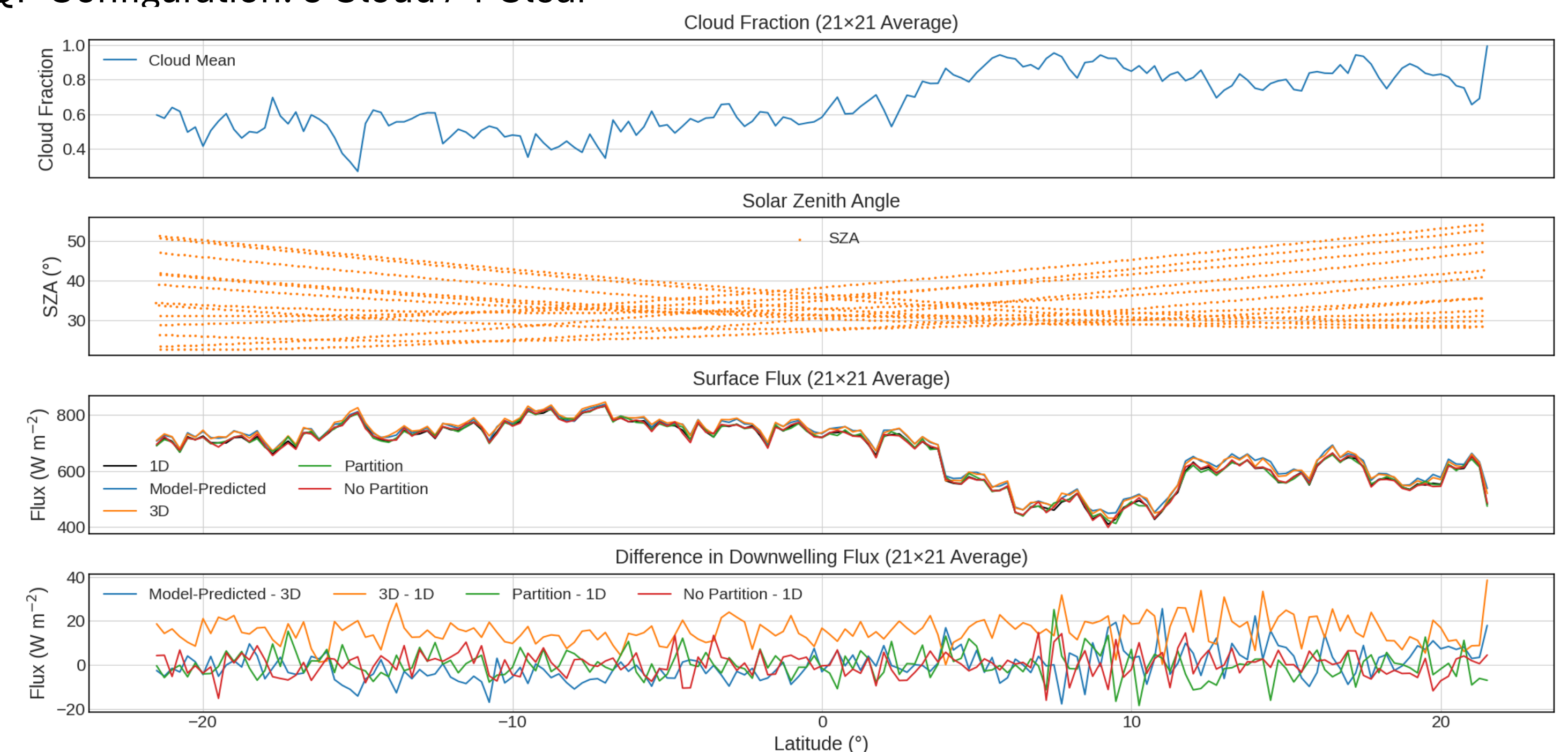

- AI/ML model captures 3D radiative effects while the GLQ method remains bound to 1D RT.

## Summary and Future Work

- AI/ML model performance trained on EarthCARE data (Sept 2024–Aug 2025)
  - RMSE values: Ocean ~30 W m<sup>-2</sup>; Land ~46 W m<sup>-2</sup>
- Speed improvement, AI/ML runs in 1.85 s/month v. 2.46 hours/month for 1D RT (Jan 2025).
- AI/ML captures complicated 3D radiative effects for cloudy scenes
- AI/ML model outperforms GLQ partitioning method, which outperforms the 1D method
- Extend the AI/ML model to off-nadir viewing geometries

### Reference:

Barker, H. W., Cole, J. N. S., Villefranque, N., Qu, Z., Velázquez Blázquez, A., Domenech, C., Mason, S. L., and Hogan, R. J.: Radiative Closure Assessment of Retrieved Cloud and Aerosol Properties for the EarthCARE Mission: The ACMB-DF Product, *EGU sphere* [preprint], <https://doi.org/10.5194/egusphere-2024-1651>, 2024.

Cole, J. N. S., Barker, H. W., Qu, Z., Villefranque, N., and Shephard, M. W.: Broadband radiative quantities for the EarthCARE mission: the ACM-COM and ACM-RT products, *Atmos. Meas. Tech.*, 16, 4271–4288, <https://doi.org/10.5194/amt-16-4271-2023>, 2023.

Mason, S. L., Hogan, R. J., Bozzo, A., and Pounder, N. L.: A unified synergistic retrieval of clouds, aerosols, and precipitation from EarthCARE: the ACM-CAP product, *Atmos. Meas. Tech.*, 16, 3459–3486, <https://doi.org/10.5194/amt-16-3459-2023>, 2023.

Qu, Z., Barker, H. W., Cole, J. N. S., and Shephard, M. W.: A cross-track extension of retrieved cloud and aerosol properties for the EarthCARE mission: the ACMB-3D product, *Atmos. Meas. Tech.*, 16, 2319–2331, <https://doi.org/10.5194/amt-16-2319-2023>, 2023.