

The MetOp-SG Satellite Attitude Control System – Challenges and Solutions

G. Wiedermann⁽¹⁾, T. Rudolph⁽²⁾, M. Vitelli⁽¹⁾, S. Winkler⁽¹⁾, R. Luzi⁽¹⁾

⁽¹⁾ Airbus Defence and Space, Claude-Dornier-Str., 88090 Immenstaad, Germany,
georg.g.wiedermann@airbus.com

⁽²⁾ ESA - ESTEC, Keplerlaan 1, Postbus 299, 2200 AG Noordwijk, The Netherlands
tobias.rudolph@esa.int

ABSTRACT

MetOp-SG is a European polar satellite system consisting of a constellation of two complementary satellites. The purpose of the mission is to provide observations and measurements for numerical weather prediction and climate monitoring, based on a total of ten instruments flown across the two satellites. MetOp-SG is the follow-on system to the first generation series of MetOp satellites, which currently provide operational meteorological observations from polar orbit. This paper presents design solutions for the AOCS subsystem covering all modes, hardware, and algorithmic solutions implemented to meet the mission requirements. Specific design challenges and solutions are discussed in detail.

1 MISSION

1.1 Overview

Building on the success of the first generation MetOp (Meteorological Operational) satellites, the MetOp-Second Generation (MetOp-SG) is the newest satellite system offering enhanced operational meteorological observations to greatly improve numerical weather prediction and climate monitoring. Additionally, the system will provide services to atmospheric chemistry, operational oceanography and hydrology making it overall a game changer for our understanding of the Earth's system [1]. The MetOp-SG programme is implemented in close collaboration between the European Space Agency and EUMETSAT. It consists of two series of satellites (termed Satellite-A 1/2/3 and Satellite-B 1/2/3) with a maximum of platform commonality between them. Each series contains three satellites to meet the required 21 years of parallel in-orbit operations, with nominal launches scheduled every 7 years. The design lifetime of each satellite is 7.5 years, while consumables are compatible with an extended lifetime of 9.5 years.

Airbus Defence and Space in Toulouse, France, has been selected as industrial prime contractor for the Satellite-A series, while the Satellite-B series is designed by Airbus Defence and Space in Friedrichshafen, Germany. The Attitude and Orbit Control System (AOCS) of both series is entirely developed in Germany.

MetOp-SG satellites will operate in a sun-synchronous polar orbit at 831 km average geodetic altitude and 9h30' local time of descending node with an orbit repeat cycle of 29 days (412 orbits in a cycle). The MetOp-SG satellites are part of the EUMETSAT Polar System Second Generation (EPS-SG) system which is constituted by the space segment, the launchers for these satellites, supporting space services for GNSS, including at least the Galileo and the GPS constellations, and a ground segment including the main ground stations for stored mission data downlink (Svalbard, McMurdo), regional ground stations for receiving Direct Data Broadcast, a Mission Command & Control Station at Svalbard and a user and services segment.

The links between the space segment and the ground segment are realised in Ka-band for mission data downlink to main ground stations, X-band for downlink to regional ground stations and S-band for the classical Command & Control functions.

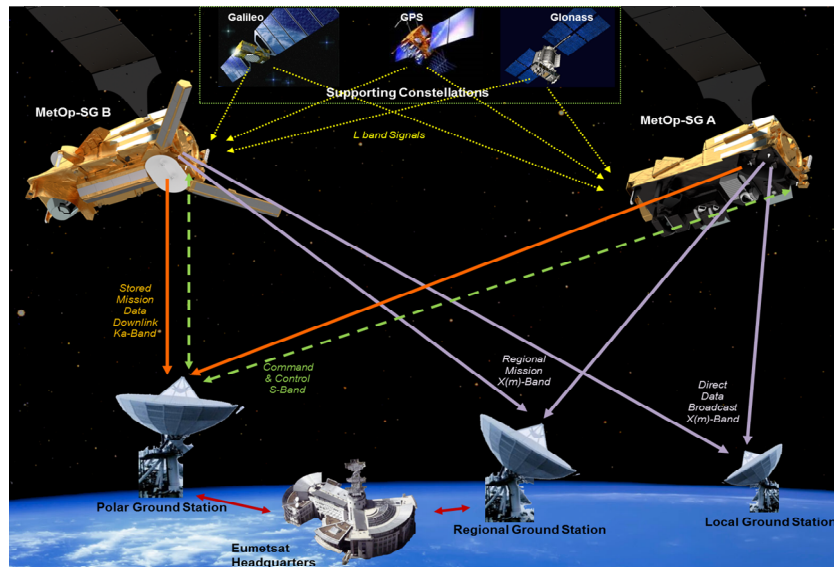

Figure 1. EPS-SG system

1.2 Global Schedule

The MetOp-SG program's accomplished key milestones are presented in the following table.

Table 1: MetOp-SG key milestones

Milestone	Date
Phase B2 Kick-off	28 May 2014
System Requirements Review	September – October 2014
Contract Signature Event	16 October 2014
Satellite Preliminary Design Review	September – November 2015
Phase C/D Kick-off	23 November 2015
Satellite-A System Critical Design Review	September – November 2018
Satellite-B System Critical Design Review	September – November 2019
Satellite-A Qualification Review	June - July 2021
Satellite-B Qualification Review	Apr-June 2022

Currently, the MetOp-SG programme is in phase D with Satellite-A1 undergoing environmental testing. For Satellite-B1, platform units have been fully integrated and AOCS equipment and closed loop testing has been completed successfully. Environmental testing will start Sep. 2023.

Each satellite, with a launch mass of about 4 tons, is set to be launched with the European Ariane 6 launcher. The first launch scheduled in Q1 2025 for Satellite-A1 and in Q4 2025 for Satellite-B1 [2].

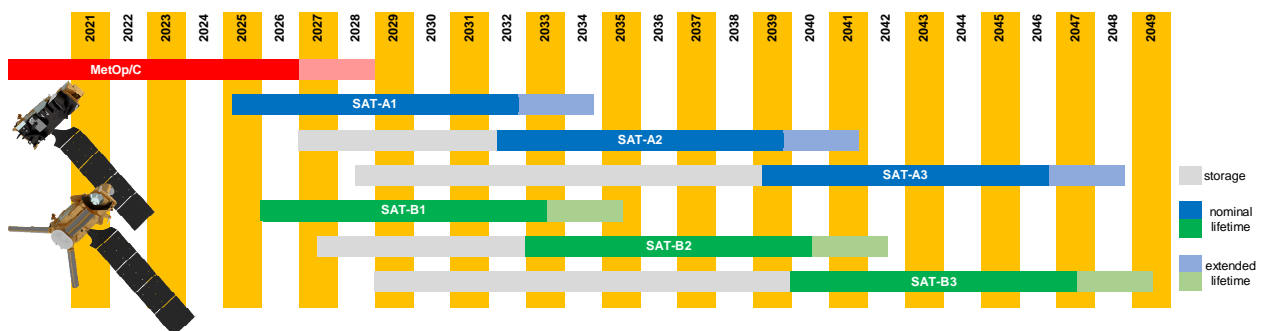

Figure 2. MetOp-SG overall schedule

2 SATELLITE DESIGN

The platform design is common to Satellites A and B. It includes the satellite structure and thermal hardware, and the platform electronic units on dedicated side panels. It also houses the propulsion module inside the launcher adaptor.

The instruments are accommodated on the nadir panel, either on the nadir side or on the zenith side. A payload equipment bay is used to accommodate the instruments electronic units.

All equipment units are mounted on the lateral panels and in the PUB (Platform Units Bay) made of Aluminium for efficient power dissipation and thermal control. All the platform units are common between satellites A and B. The differences are limited to:

- 3 Ka-band chains on Satellite-A and 2 on Satellite-B,
- 4 battery modules on Satellite-A and 3 on Satellite-B,
- Number of solar cells on the solar array adapted to the reduced needs of Satellite-B,
- 5 wheels on Satellite-A, and an extra wheel on Satellite-B for instrument angular momentum compensation.

Table 2: MetOp-SG mission and satellite properties

Property	Satellite-A	Satellite-B
Launch mass	4 tons (incl. ~800 kg fuel)	3.8 tons (incl. ~800 kg fuel)
Overall height	7 m	6.6 m
Inertia x/y/z deployed	9000 / 16500 / 21000 kgm ²	9500 / 14500 / 2000 kgm ²
Mean power	2.9 kW	2.1 kW
Data rate day / night / peak	66 / 28 / 80 Mbps	71 / 71 / 80 Mbps
Design life	7.5 years, consumables for 9.5 years	
Orbit	Polar sun-synchronous, 9h30 local time, 831 km altitude, 98.7 deg inclination, 29 days repeat cycle	
Launcher	Ariane 6	

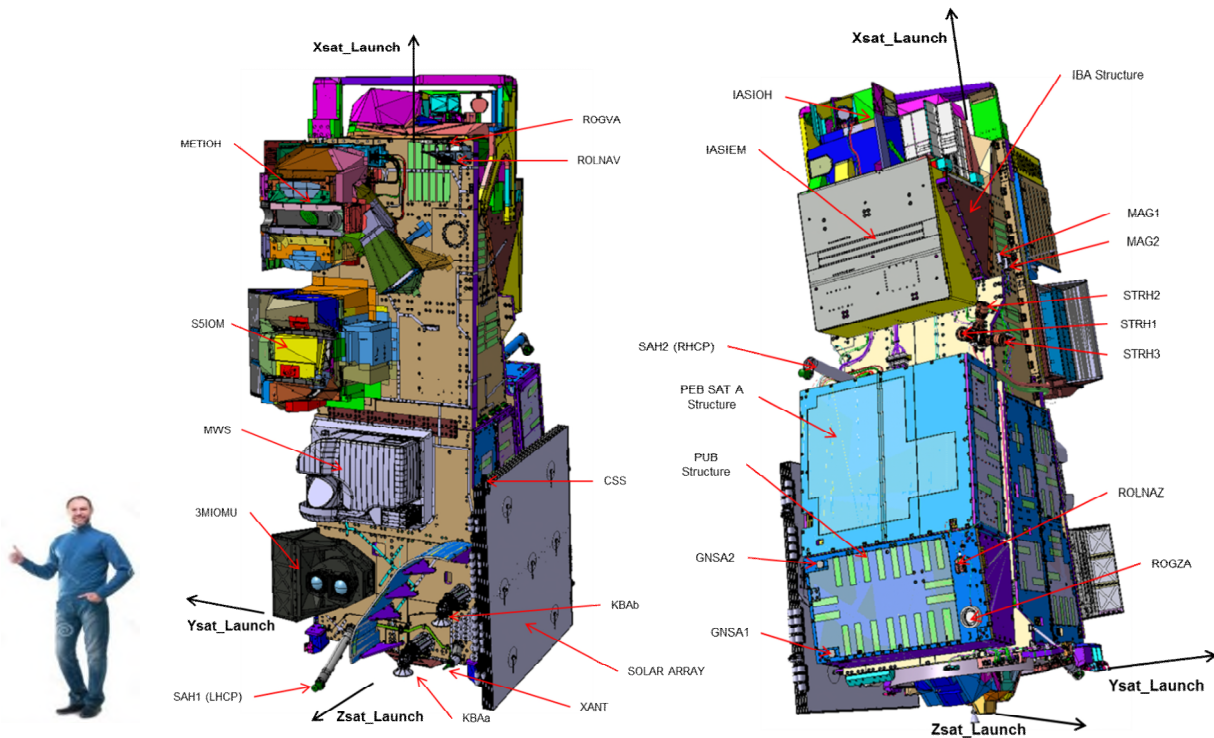

Figure 3. MetOp-SG Satellite-A stowed

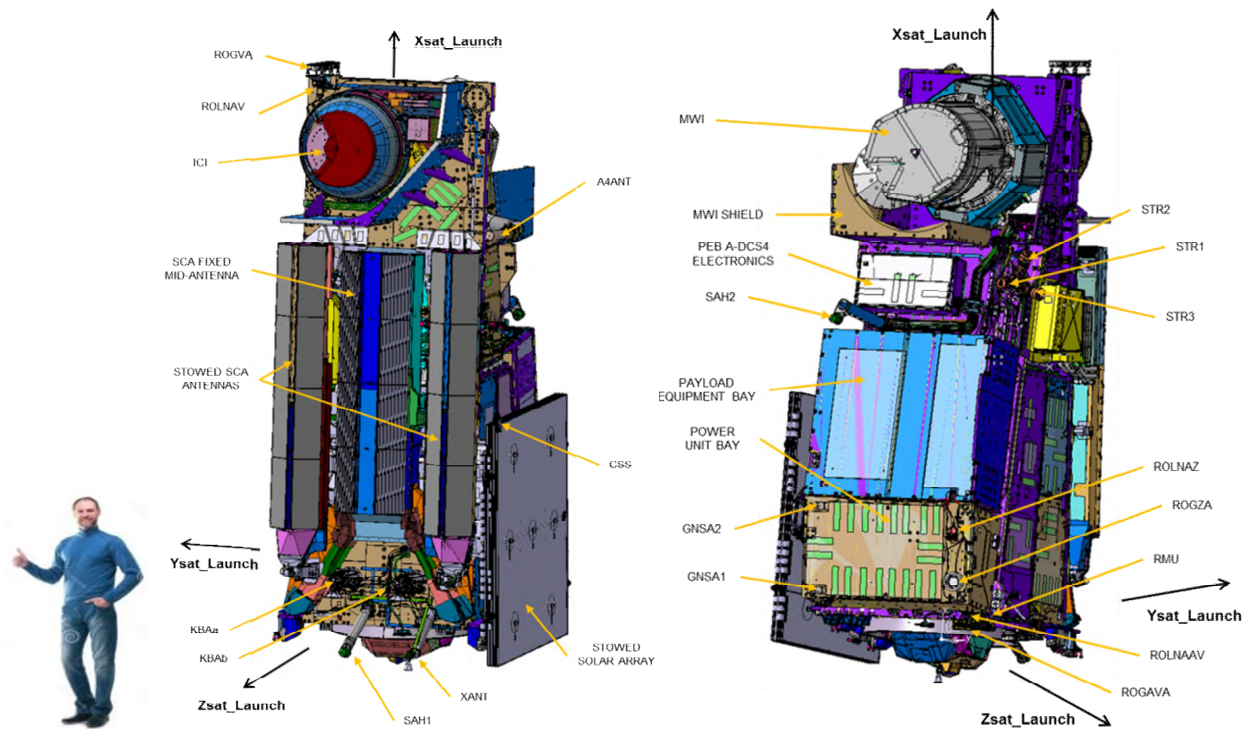

Figure 4. MetOp-SG Satellite-B stowed



Figure 5. MetOp-SG Satellite-A and Satellite-B in flight configuration

In terms of payloads, Satellite-A and Satellite-B are complementary. Satellite-A is focusing on optical instruments and atmospheric sounders, while Satellite-B is equipped with microwave instruments. The ten different instruments to be flown on the two satellite series include six Contractor Provided Item (CPI) instruments that are developed under the MetOp-SG contracts: MWS (MicroWave Sounder), MWI (MicroWave Imager), ICI (Ice Cloud Imager), SCA (SCAtterometer), 3MI (Multi-viewing, Multi-channel, Multi-polarization Imager), and RO (Radio Occultation sounder). In addition, four Customer Furnished Item (CFI) instruments are provided by ESA Copernicus, DLR and CNES via EUMETSAT: Sentinel-5 (ESA Copernicus), METimage (DLR), IASI-NG (CNES), and Argos-4 (CNES) [1].



Figure 6. MetOp-SG Payload Overview

3 AOCS Architecture

3.1 Overview

During nominal operation the AOCS provides local normal pointing with yaw steering with medium accuracy as required for instrument operation. Attitude knowledge is provided by fusion of the three star trackers in a close to orthogonal configuration. The required attitude knowledge allows a cost efficient and simple gyro-less solution.

Knowledge of satellite position and velocity is provided by a Global Navigation Satellite System (GNSS) receiver compatible with GPS and Galileo constellations which feeds an orbit propagator to ensure position and velocity knowledge also in the case of GNSS receiver outage.

The control torques is applied by an array of reaction wheels with autonomous, continuous magnetic de-saturation of the accumulated momentum due to disturbance torques. The slews required for out-of-plane orbit manoeuvres and instrument calibration in the commissioning phase are implemented using thrusters for actuation to allow short manoeuvres without exceeding the wheel momentum capacity.

To compensate the Microwave Imager (MWI) and Ice Cloud Imager (ICI) exported torque and momentum on Satellite-B an additional reaction wheel is implemented and rate and acceleration telemetry is provided by the instruments for feed-forward to the reaction wheels array. The AOCS is designed to handle increased exported torque due to failure of the scan control electronics without transition to safe mode to ensure minimum impact on the satellite operations.

Instrument operation is supported by the detection and prediction of orbital events needed for instrument operation like eclipse transition, solar zenith angle transition of the instrument field of view or sub-satellite point on ground, and sun entry in the instrument calibration field of view.

Further AOCS provides the guidance for the Ka-band antenna pointing mechanism to ensure correct pointing of the antenna to the ground station and the solar array steering.

Orbit control is performed with three thruster configurations for in-plane and out-of-plane manoeuvres, anti-velocity manoeuvres without the need for satellite slews, and controlled re-entry manoeuvres with high thrust using a 400 N central thruster.

For initial acquisition after launcher separation and solar array deployment and in case of severe satellite failures a biased B-dot control safe mode is used. The mode provides a robust rate and attitude control of the satellite by aligning the negative pitch axis to the orbit normal axis and by building-up and maintaining the desired rate bias and angular momentum about the pitch axis with the help of the reaction wheels. At first, a canted four thruster configuration provides three axis control torques for fast damping of the initial satellite rates deduced from the change of the magnetic field. Once the initial rates are damped, the attitude control is provided by magneto-torquers. The bias momentum in the pitch axis provides gyroscopic stiffness around the yaw axis. Actuation by magneto-torquers allows to avoid use of consumables.

The solar rotation is steered using a coarse Sun sensor on the solar array which allows reliable power generation as soon as a low spacecraft rate has been achieved during the rate control safe mode. The Earth-pointing is reached via thruster-based Orbit control mode. The transition from safe mode to orbit control mode is armed by Ground and it happens automatically when the satellite attitude is sufficiently close to Earth pointing.

The large delta-V manoeuvres for controlled re-entry are performed with the central 400 N thruster with yaw slews before and after each manoeuvre. After initial orbit lowering to 750 km perigee the AOCS is switched to thruster based control of the Earth pointing attitude between boosts to compensate the high aerodynamic disturbance torques.

Commonality of the space-to-ground interface and operations is ensured by a common AOCS between Satellite-A and Satellite-B with the exception of the number of reaction wheels and the MWI / ICI torque and momentum compensation. The equipment, the algorithms and the software code are fully common with only specific parameterisation to account for the differences between the satellites.

The MetOp-SG AOCS reference is based on the AS400 product (today merged into AstroBus NEO) for risk mitigation and cost efficiency and re-uses the overall architecture, the modes, algorithms, and software modules with specific evolutions to comply with the MetOp-SG requirements.

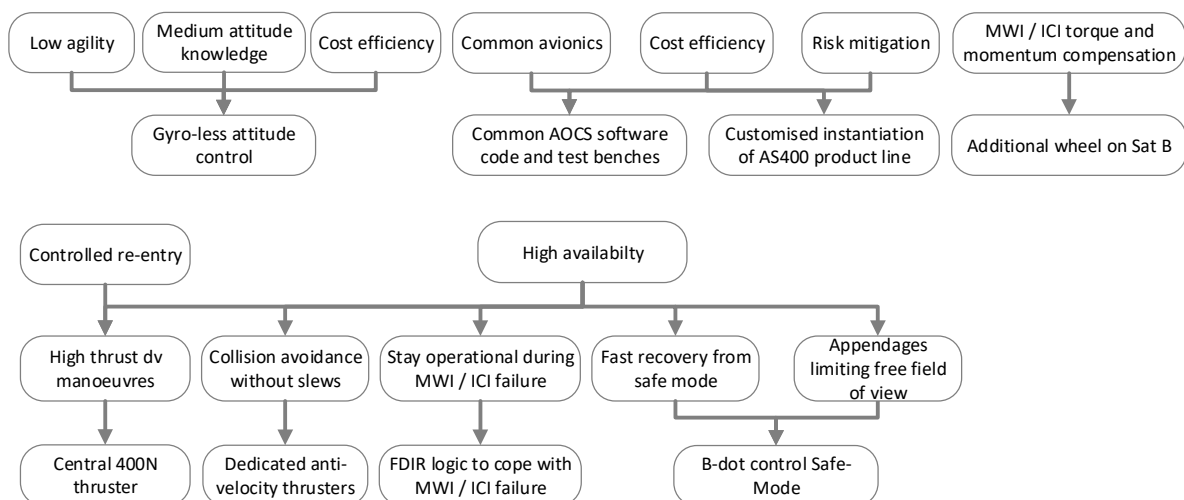

Figure 7. MetOp-SG AOCS design derived from mission needs

Table 3: MetOp-SG AOCS functionality and performance

AOCS Functionality	Implementation
Local normal pointing with yaw steering	Gyro-less control based on star tracker and reaction wheel actuation and autonomous, continuous magnetic de-saturation
Microwave imager and ice cloud imager torque and momentum compensation	Additional reaction wheel on Satellite-B, rate and acceleration feedback from instruments
Slews for out-of-plane orbit control, re-entry and calibration	Thruster actuated slews with canted four thruster configuration
Controlled re-entry	Delta-v manoeuvres with central 400 N thruster, Thruster based Earth pointing on low perigee orbits (< 750 km)
Anti-velocity thrust without slews	Dedicated thrusters in anti-velocity direction, attitude control by reaction wheels (only short manoeuvres)
Orbit control manoeuvres	Canted four thruster configuration with off-modulation
High thrust orbit control and controlled re-entry manoeuvres	Central 400 N thruster, on-modulation of canted four thruster configuration
Biased B-dot control safe mode	Thruster based rate damping, bias momentum stabilisation of pitch axis, steady state rate control with magneto-torquers, no consumables used in steady state, solar array steering by coarse Sun sensor
Satellite position and velocity knowledge	GNSS (GPS and Galileo) receiver and on-board orbit propagator
Solar array steering	Reference angle computation, coarse Sun sensor for steering in safe mode
Ka-band antenna guidance	Azimuth and elevation for ground station pointing provided
Ancillary data	E.g. Orbital events detection and prediction, orbit number and angle, heliocentric velocity for star tracker, acceleration for GNSS receiver
Required AOCS Performance	
Acquisition and Safe Mode: Angle between satellite –YSAT_FLIGHT axis and orbit normal <30 deg in less than 125 min (100% of the cases) Nominal pointing: Absolute knowledge error (AKE): 95 µrad per axis (68.3% mixed interpretation) Absolute performance error (APE): 300 µrad per axis (68.3% temporal interpretation) Pointing Stability: Set of stability requirements enveloping the system stability needs. Slews: up to 0.3°/s slew rate	Orbit Control Mode: Max. APE 5° (99.7%) x-axis and transverse, 2° average y and z-axis for out-of-plane manoeuvres Position knowledge: radial 5m, cross / along track 10m , (68.3%, mixed) Orbit propagator: max. 1° pointing error after 1 orbit

3.2 Operational Modes

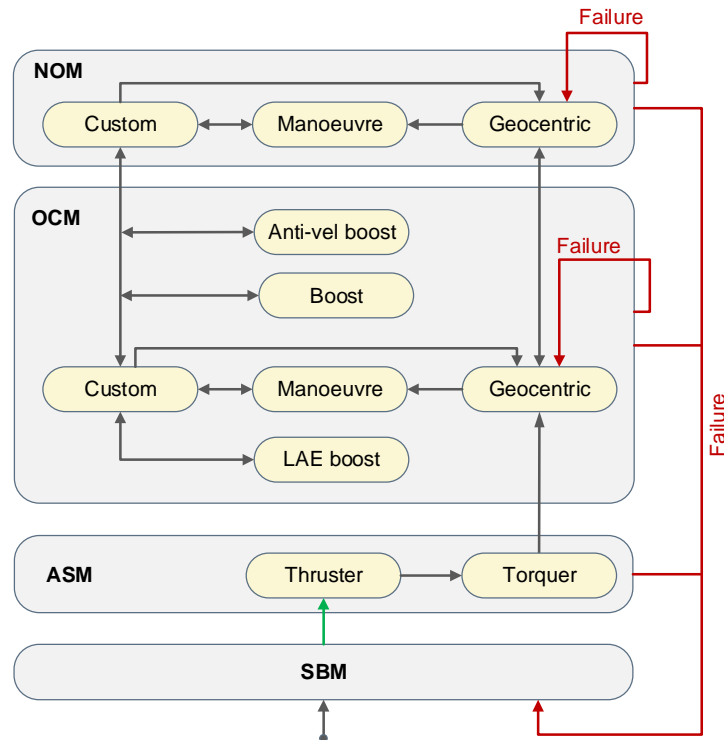

Figure 8. MetOp-SG AOCS mode diagram

The on-board algorithms for the attitude and orbit control system are subdivided into the following four AOCS modes:

Stand-by Mode (SBM)

When operating in this mode, the AOCS does not perform any autonomous control activities. However, sensors and actuators are processed and can be manually commanded.

Acquisition and Safe Mode (ASM)

The ASM implements initial acquisition and safe mode attitude control with two sub-modes for thruster based rate damping and magneto-torquer controlled steady state operation. Rate measurement is provided by differentiation of the magnetic field measured by the magnetometer.

Normal Mode (NOM)

The geocentric accurate pointing sub-mode provides robust three axis attitude control as entry point to NOM and is also used as fall-back mode in case of failures detected in other NOM sub-modes. The attitude manoeuvre sub-mode implements small attitude manoeuvres. Larger slews are performed with thruster actuation in OCM to cope with the high satellite inertia. The custom accurate pointing sub-mode allows following attitude profiles, in the case of MetOp-SG local normal pointing with yaw steering.

Attitude control is based on star tracker and GNSR measurements with the control torques applied by a reaction wheel array with continuous magnetic de-saturation. The normal mode is robust to cover disturbance torque transients caused by solar array drive rate changes, Ka-band antenna pointing mechanism operation and MWI and ICI scan control electronics failure.

Orbit Control Mode (OCM)

The geocentric accurate pointing sub-mode again provides robust three axis control similar to the NOM but with the canted four thruster configuration used for actuation instead of reaction wheels.

The attitude manoeuvre sub-mode implements thruster based slews for out-of-plane or retro-grade manoeuvres which require a yaw slew and instrument calibration roll slews. The custom accurate pointing sub-mode is used for stabilisation after slews or boosts. During re-entry operations at low perigee orbits geocentric accurate pointing is the default mode for attitude hold between delta-V manoeuvres.

The orbit control mode provides sub-modes for three different types of boosts. In the anti-velocity boost sub-mode the anti-velocity thrusters are used to lower the orbit without the need for satellite slews. Attitude control is provided by off-modulation and reaction wheels for these short manoeuvres. The liquid apogee engine boost sub-mode provides high thrust delta-V manoeuvres with the central 400 N liquid apogee engine for re-entry manoeuvres with attitude control by on-modulation of the canted four thruster configuration. The boost thruster sub-mode provides delta-V using the canted thruster configuration with off-modulation for attitude control.

Boost modes are also directly accessible from NOM for short in-plane manoeuvres and anti-velocity boosts to avoid accumulation of unwanted thruster pulses in other OCM sub-modes.

Reference Attitudes and Attitude Manoeuvres

The MetOp-SG AOCS provides the following reference attitudes and attitude manoeuvres

- Local normal pointing with and without yaw steering
- Local tangential pointing plus bias as needed to align the thrust vector with the satellite velocity vector for orbit manoeuvres
- Up to 180° yaw slews for attitude manoeuvres and
- 120° roll slew for instrument calibration

3.3 Equipment

The AOCS utilises star trackers (STR), GNSS receiver (GNSS), magnetometers (MAG) and a coarse Sun sensor (CSS) as sensors and reaction wheels (RW), magneto-torquers (MTQ) and thrusters (THR) as actuators. Further AOCS controls the rotation of the solar array drive assembly (SADA) and provides guidance for the Ka-band antenna pointing mechanism (APM).

The AOCS equipment is connected to the on-board computer (OBC) either directly by a redundant MIL-STD 1553B bus or via a remote interface unit (RIU).

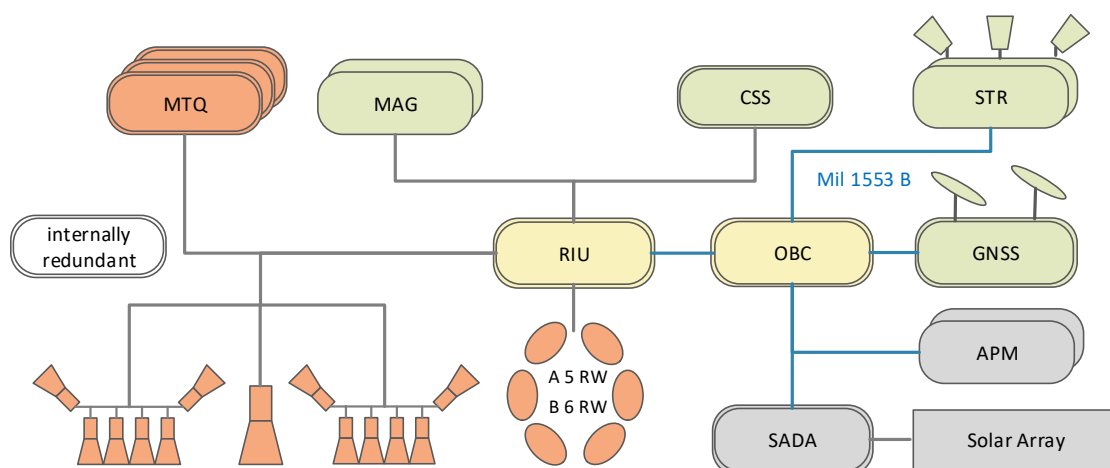

Figure 9. MetOp-SG AOCS hardware configuration

Table 4: MetOp-SG AOCS equipment baseline

Equ.	#	Redundancy	Supplier	Comment
MAG	2	Cold redundant	ZARM Technik	Fluxgate sensor
CSS	1	Int. cold redundant	Moog Bradford	Pyramid type
STR	3	2 out of 3 hot red.	Sodern	Multiple head, APS sensor
GNSS	1	Int. cold redundant	Airbus	GPS & Galileo, single frequency, Seavey patch antenna
MTQ 400 Am ²	3	Int. cold redundant	ZARM Technik	
RW 65 Nms	5 / 6	4 out of 5 hot red. 5 out of 6 hot red.	Rockwell Collins	
Prop. system	1	Int. cold redundant	Airbus	
THR 20 N	2 x 6	Branch cold red.	Moog-ISP	4 canted thrusters in velocity direction, 2 anti-velocity thrusters
THR 400 N	1	8 x 20 N as backup	Airbus	
Fuel tank	1	None	Airbus	
SADA	1	Int. cold redundant	Kongsberg	Continuous rotation with slip rings
SA	1	Internally redundant	Airbus	
APM	2	Cold redundant	Kongsberg	
RIU	1	Int. cold redundant	RUAG Sweden	
OBC	1	Int. cold redundant	Airbus	

3.4 Algorithms and Software

The algorithms are mostly re-used from the Airbus AS400 product. Evolutions and customisations to MetOp-SG needs comprise:

- Acquisition and Safe Mode with thrusters as actuators to cope with high inertia
- Thruster sub-mode for the 400 N liquid apogee engine used for controlled re-entry
- Thruster sub-mode mode for anti-velocity boost with two anti-velocity thrusters
- MWI / ICI instrument torque and momentum compensation on Satellite-B
- Solar array steering
- Ka-band antenna pointing mechanism guidance
- Controlled re-entry with satellite operation at low perigee elliptical orbits (400 km perigee nominal, 250 km perigee backup case)
- Orbital events detection

A common set of algorithms is used for both satellite to ensure cost efficient development and verification, common ground interface and operations and low risk of errors due to repeated testing. The differences between the two satellites are accounted for in the algorithm parameterisation. The Modes and Control Laws (MCL) algorithms are implemented in Matlab/Simulink. Automatic code generation is used to produce the on-board flight code.

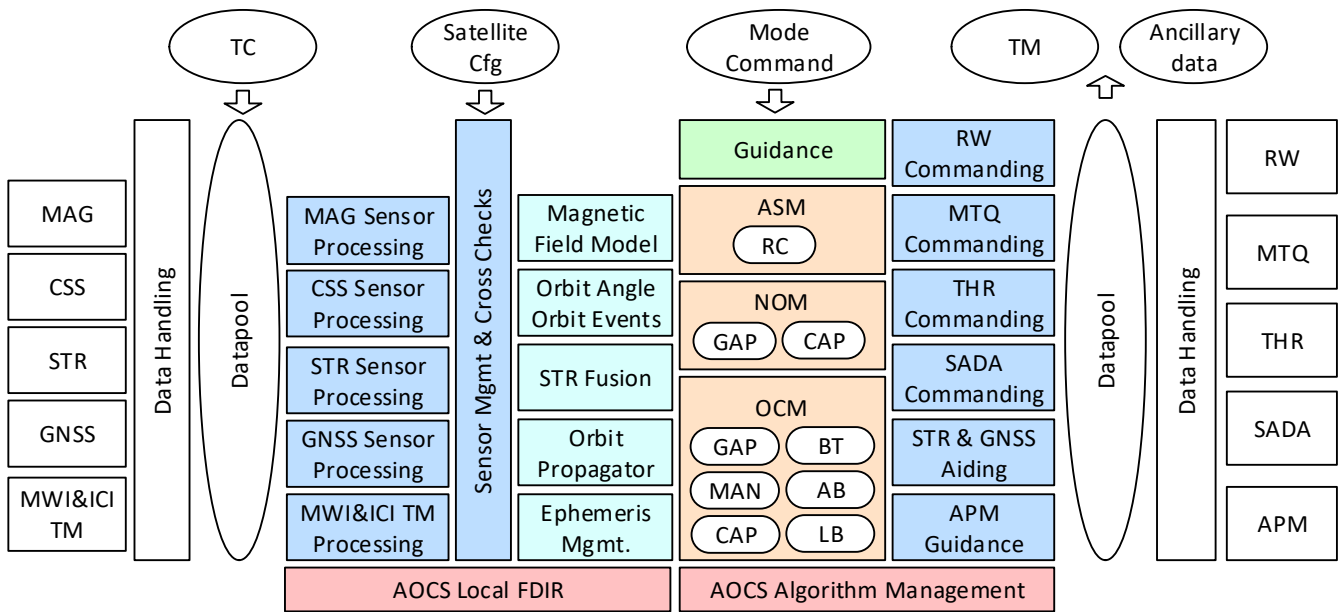

Figure 10. MetOp-SG AOCs algorithm architecture

4 SPECIFIC SOLUTIONS

4.1 Robust OCM Design

The focus of this section is on the estimation & control solution to perform delta-V manoeuvres using chemical (ON/OFF) thrusters.

To ensure robustness of the closed attitude control loop, variations and uncertainties in the spacecraft plant are considered including spacecraft mass properties, cantilever frequencies of structural appendages, solar array angle and tank pressure. This can lead to well over 1000 three-axis LTI plants per delta-V mode depending on the selected sampling granularity, see example depicted in Figure 11. The controller synthesis shall achieve a large static controller gain to enable good disturbance (mainly induced by delta-V thrusters) rejection. It shall further ensure classical (pseudo-) SISO stability margins of 6 dB and 30 deg in gain and phase, respectively, as well as 0.5 modulus margin. Flexible resonances caused by structural appendages (solar array, antennas) shall be gain rejected by 6 dB. Propellant sloshing modes can be phase stabilized. Because due to the partially very low sloshing frequency, gain stabilization of sloshing modes would lead to very small control loop bandwidths, i.e. small controller static gains, and thus bad disturbance rejection.

For stability validation, the hybrid multi-rate closed control loop is analysed considering the individual sampling rate of each sensor, actuator and the AOCs algorithm.

Because of the complexity of the plant, the controllers are synthesized by a structured H-infinity approach (numerical optimization) using Matlab. The complexity results from:

- (1) the sloshing modes distribution over a wide frequency range due to propellant tank pressure and delta-V thruster modulation ratio
- (2) the small frequency separation of sloshing and flexible modes. Because the required mode rejection needs a significant drop of loop gain within this small frequency range, but ideally without phase drop causing loss of stability margin.

An integral part of the controller is needed for zero (static) disturbance transmission and is formulated as a disturbance torque estimator/compensator. This allows to estimate the disturbance and reuse it to initialize the estimator in subsequent delta-V boosts to ensure faster disturbance rejection, thus better attitude performance.

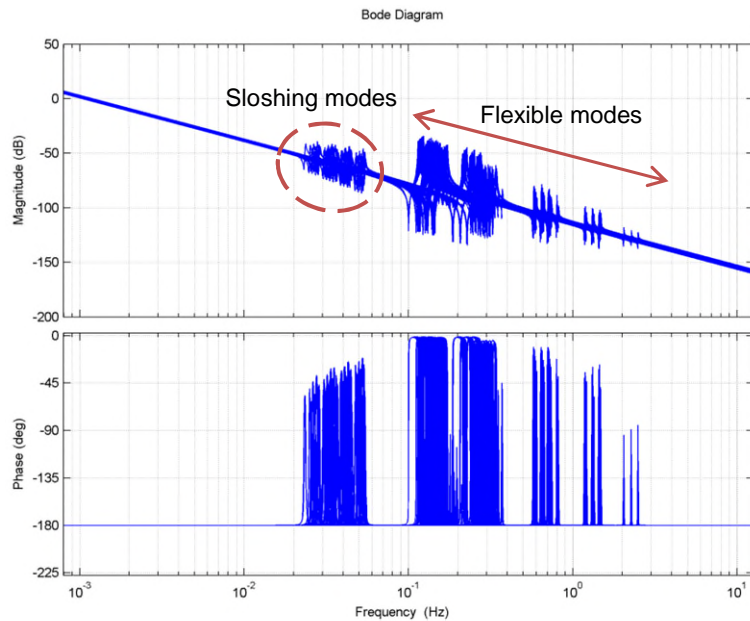

Figure 11. Exemplary linearized single-axis plant model (torque \rightarrow angle)

4.2 Controlled Re-entry

Uncontrolled re-entry of the MetOp-SG satellites would result in a high number of debris coming either from the platform units or instruments, leading to unacceptable casualty risk. To provide a safe design and decrease the casualty risk at its minimum, the satellites will perform a controlled re-entry over the South Pacific Ocean Uninhabited Area (SPOUA).

For a robust and reliable disposal, controlled re-entry is performed in 3 steps. Phase 1 decreases the altitude to avoid any interaction with the rest of the constellation. Phase 2 nominally decreases the perigee in only two boosts (plus an initial LAE calibration boost). Phase 3 is dedicated to the last boost that puts the satellite on its final re-entry orbit. To maximize the re-entry reliability, a back-up scenario is possible in case of Liquid Apogee Engine (LAE) failure using both branches of 20 N thrusters in parallel.

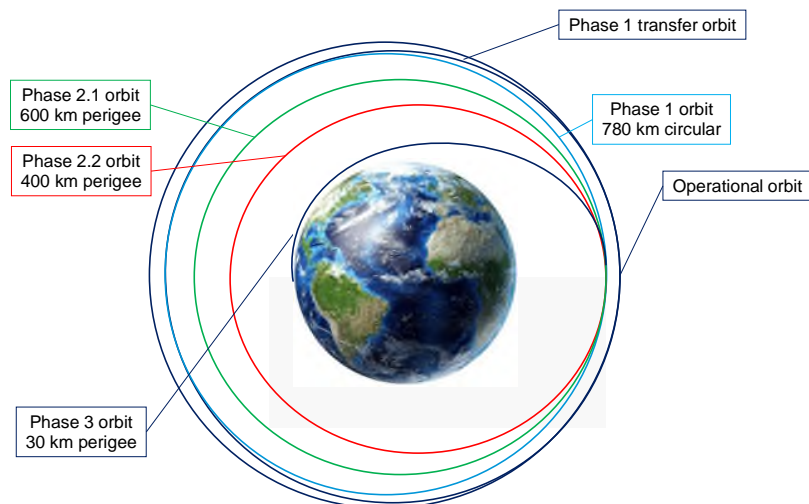

Figure 12. MetOp-SG controlled re-entry

Over the life of the satellite the blow down propulsion system is re-pressurised several times, including at the start of the re-entry phase and before the final boost. About 460 kg of the total fuel mass of 760 kg are needed for the re-entry phase.

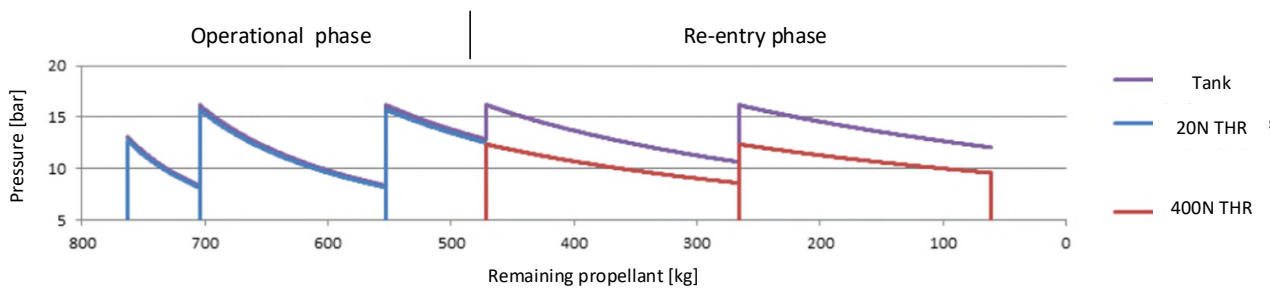

Figure 13. Pressure over remaining propellant

4.3 Instrument Compensation

The MWI and ICI instruments present on Satellite-B have both a significantly rotating part (24.9 and 8.97 kg·m² respectively) and rotate at -45 rpm around opposing axes (-z and +z respectively), thus yielding a total angular momentum of 75 Nms.

In order to improve the AOCS performance an instrument compensation function is implemented on-board, which includes:

- Estimation of the MWI and ICI exported torque and angular momentum based on the velocity and acceleration measurements provided by the instruments. In order to avoid transferring measurement noise into the attitude control loop a dead-band is applied, which filters out low estimated torque and thus guarantees compensation occurs only during the spin-up and spin-down phases.
- Compensation of the angular momentum by the reaction wheel array in NOM and OCM modes, allowing, in particular to achieve zero total angular momentum in NOM.
- Compensation of the exported torque during the spin-up and spin-down phases in order to improve the pointing performance during these transients. The estimated torque is compensated by feed-forward control in the attitude controller. The gyroscopic torque generated by the MWI and ICI is also compensated.

4.4 Pointing Budget with PEET

The pointing budgets describe the system behaviour regarding numerous requirements such as attitude performance and knowledge, geolocation performance and instrument spatial co-registration. The pointing error engineering process used in MetOp-SG is in line with the classical Validation & Verification process and divided into

- (1) Apportionment: break-down of the overall pointing error requirement (PER) to allocate fractions of it to different levels: unit, subsystem & instruments, system.
- (2) Budgeting: characterize the pointing error sources (PES), analyse their pointing system transfer (dynamic, static), determine their error index contribution in view of the statistical interpretation and finally quantify the pointing error contributors (PEC) to the system pointing error budget. It is based on ECSS documents [3], the EPEE Handbook [4] and the ESA PEET software.

The practical implementation of the pointing error process is shown in Figure 14. The modelling and computation of the pointing budget is done in the ESA PEET software. The exchange of data among subsystem, instrument and the system teams is realized via an Excel template and the PEET model. This ensured that the sub-budgets are transparent and in line with the approach and nomenclature defined in [4], reduced the number of budgeting iterations and enabled the quick identification of discrepancies in the sub-budgets.

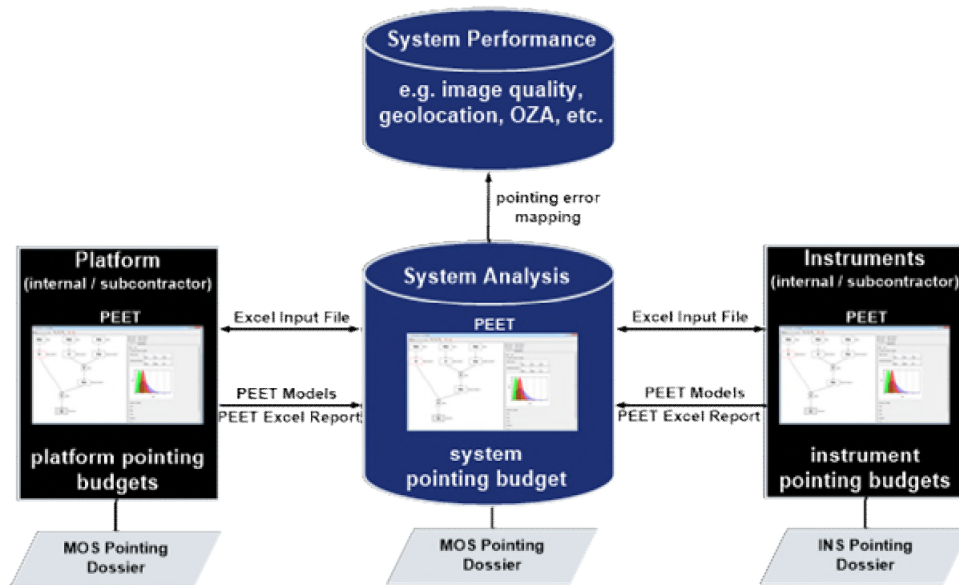

Figure 14. Pointing error engineering process implementation in MetOp-SG (OZA: observation zenith angle)

4.5 Orbital Events Detection

The AOCS is supporting operations and instrument scheduling by signalling instantaneous as well as predicted occurrences of several orbital events, necessary for 3MI, METI and S5:

- Leading or trailing edge of the instrument field of view (FOV) on the Earth surface passes a defined solar zenith angle (SZA) threshold
- Eclipse entry or exit of the satellite
- Sun entry in the instrument calibration FOV

The instruments FOV is a projected rectangle on the Earth's surface, which is defined by three vectors as illustrated:

- Leading edge (crossing SZA line first)
- Trailing edge (SZA line leaving rectangle)
- Sub-satellite point (Nadir)

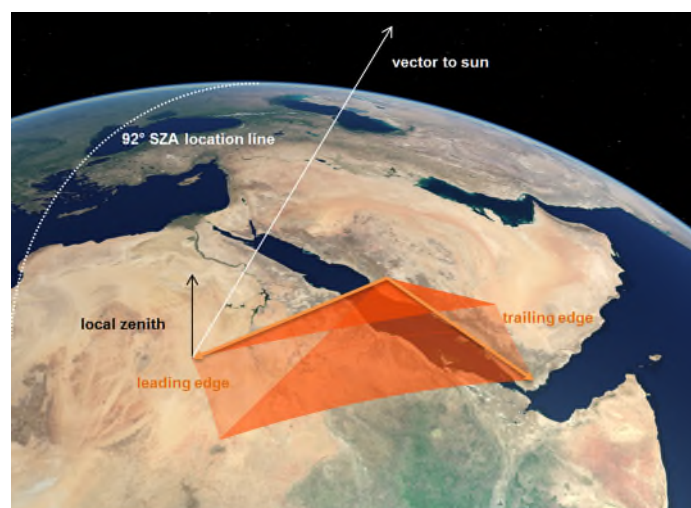

Figure 15: Example illustration of the FOV definition by two vectors for a 92 deg SZA threshold

The corresponding SZA is defined by first intersecting a straight line going through the S/C CoM and having the direction of the leading/trailing instrument edge and the Earth ellipsoid. At this point the gradient of the ellipsoid function is evaluated and gives the local zenith vector; the angle between this vector and the inertial Sun vector representing the local SZA. Comparing the computed SZA with the predefined threshold leads to the triggering of the associated event.

For the prediction of the orbital events a propagation of the S/C position, velocity and attitude is applied.

The eclipse model implemented in the AOCS algorithm considers an ellipsoid shape for the Earth and a spherical shape for the Sun. To determine whether the S/C is in full eclipse, the cone connecting the S/C to the Sun limb is defined. If all the cone's lines intersect the Earth ellipsoid, then the S/C is considered to be in full eclipse.

To raise the Sun calibration event, the angle between the vector from the S/C to Sun centre and negative z-axis of the S/C frame is first computed by taking the scalar product of the two vectors. Then, when the computed angle crosses the defined threshold, the event is raised. As for the FOV intersections, propagation is necessary in order to predict the event occurrence.

5 CONCLUSION AND OUTLOOK

At the time of writing integration of the first satellite models is well advanced and integration of the second Satellite-B flight model has started. Mechanical testing has been performed for the Satellite-A proto flight model and thermal vacuum testing is on-going. Functional verification with closed loop tests, mission tests and system tests together with EUMETSAT is running at full speed. Looking forward to a successful completion and launch!

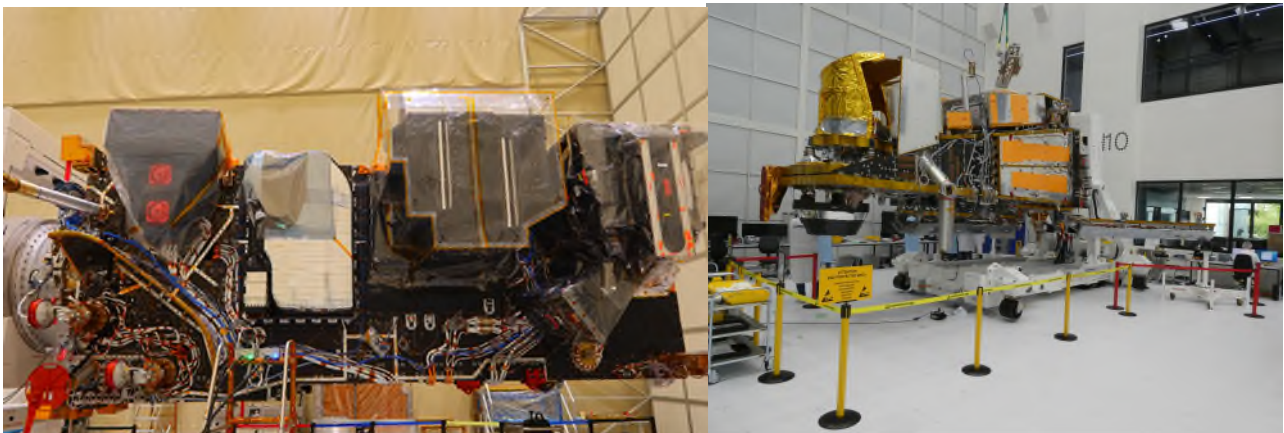

Figure 16: Satellite-A and Satellite-B during integration in the clean room

6 REFERENCES

- [1] ESA EOP internet portal, <https://www.eoportal.org/satellite-missions/metop-sg#overall-metop-sg-objectives>, 5th of April 2023
- [2] EUMETSAT internet portal, <https://www.eumetsat.int/our-satellites/metop-series?sjid=future>, 5th of April 2023
- [3] Space engineering Control performance, ECSS-E-ST-60-10C, Issue 01, Nov. 2008
- [4] ESA pointing error engineering handbook, ESSB-HB-E-003, Issue 1, rev. 0, 19/07/2011