

# SATELLITE DAMAGE SENSOR SUPPORTING MULTIPLE IMPACTS FROM SPACE DEBRIS

**Kevin Theuma<sup>(1)</sup>, Robert Camilleri<sup>(2)</sup>**

<sup>(1)</sup> *Institute of Aerospace Technologies, University of Malta, Msida, MSD2080, Malta,  
+356 2340 2072, kevin.theuma@um.edu.mt*

<sup>(2)</sup> *Institute of Aerospace Technologies, University of Malta, Msida. MSD2080, Malta,  
+356 2340 3140, robert.c.camilleri@um.edu.mt*

## ABSTRACT

The ever-increasing number of earth-orbiting spacecraft and disused space junk is resulting in a dramatic rise in the risk of space debris impacting and damaging satellites and thereby negatively impacting the transmission of the internet, TV, radio, GPS and most telecommunications on Earth. While sense and avoid technologies are used for debris larger than 10mm, debris smaller than 10mm can remain undetected. Moreover, due to weight considerations, satellite shields are not always equipped to withstand hypervelocity impact of objects between 1mm and 10mm. While traditional material testing achieves a pass or no pass criteria, there is a significant requirement to detect impacts and quantify the level of damage following an impact. This is important to determine whether the satellite needs to be repaired or replaced. The paper proposes a smart surface technology for satellite shields that detects impact, locates damaged regions and quantifies damage by space debris. This surface consists of a network of resistive tracks that are arranged in multiple layers. When the smart surface is hit by space debris, the damage caused by the impact breaks the resistive tracks at the point of impact. The broken tracks are identified and used to determine the damaged areas. The results show that the mesh supports the detection of damage from multiple impacts. They also show that for the accurate determination of their size and shape of the damage, the resolution of the mesh needs to be improved to the sub-millimetre level.

## 1 INTRODUCTION

This paper presents a smart surface for satellite shields. The smart surface is able to detect impact and locates regions of damage. In recent years, the satellite market experienced a paradigm shift with the rise of small satellites and constellations formed by hundreds of satellites. It is anticipated that by 2026, more than 300 satellites per year will be launched, representing a market of \$304 billion [1]. However, the increase in satellite density in orbit, and the large amount of space debris orbiting in space, poses a threat to such satellites.

Space debris is any man-made objects in orbit that no longer has a useful purpose, and can be classified in three categories according to size: smaller than 1 mm, between 1mm and 10mm, or larger than 10 mm. This debris poses a threat because it can collide with satellites that are still operational and may thus disrupt satellite-dependent services such as telecommunications and satellite navigation systems. The latter can be detected by radars and optical sensors, and satellites in their path would take evasive manoeuvres [2]. For example, the U.S. Space Surveillance Network is capable of detecting space debris in the low-Earth orbit that is larger than 50mm [3]. On the other side of the spectrum, debris smaller than 1mm is addressed by satellite shields that are designed to withstand their impacts. Therefore, these pose no real danger to orbiting satellites. However, space debris between 1mm and 10 mm at low Earth orbit (where velocities are over 5 km/s) offer a threat to

orbiting satellites as they are too small to detect by in-situ technologies and contain significant kinetic energy to damage the satellite shield [2, 4]. Continuous research efforts aim to understand the behaviour of the shields under hypervelocity impacts through the use of characterisation experiments which produce iterative improvements in shield design [5-7]. While traditional material testing achieves a pass or no pass criteria, there is a significant requirement to detect impacts and quantify the level of damage following an impact. Such awareness is important to establish if the satellite needs to be repaired or replaced.

Barilaro et al. [8] investigated a proof of concept based on Thin Film Heat Flux Gauges. On impact, the kinetic energy is converted to heat, which is indicative of the scale of impact. However, it was shown that the results were influenced by conjugate mechanical and thermal effects, which were difficult to separate and distinguish. Conversely, Hamilton et al. [9] developed a technology that uses a combination of acoustic sensors and resistive grid to localise and assess the extent of the impact. While the multiple acoustic sensors and triangulation techniques establish the location of the damage, the resistive grid is used to measure the size of the damaged area. The resistive tracks normally conduct electrical current but when an impact occurs, some of the tracks break and thus they stop conducting current. Consequently, the overall resistance of the grid increases. The change in resistance is exploited to determine the size of the damaged area.

This work aims to advance this field by developing a concept for a smart material, which is able to detect impact and quantify damage to the shield. In contrast to the work by Hamilton et al., the technology developed in this paper makes use of a grid of resistive tracks both for detection, locating the position of damage and quantifying damage to the shield. The technology can support detection of more than one impact. To demonstrate this, the paper is organised in the following manner: the conceptual design is described in Section 2. The design of experiment is described in Section 3 and the Results presented in Section 4. Finally, a conclusion is drawn and presented in Section 5.

## 2 CONCEPTUAL DESIGN

This paper develops a smart surface to detect impact from space debris, locates the damaged region and quantifies the damage. The smart surface consists of four layers, with each layer having parallel tracks forming the resistive circuit. Each layer is offset from one another by 45 degrees. When the smart surface is penetrated by debris, the resistive tracks on the various layers are broken at the point of impact. The different orientation of the resistive circuit in each layer allows us to establish the point of impact by finding where the broken resistive tracks intersect. For example, consider a mesh with two layers: one with vertical resistive tracks and another one with horizontal resistive tracks as shown in Figure 1a. If the layers are impacted, the resistive tracks are broken. The damaged area is represented by the red circle in Figure 1b. The points at which the broken vertical and horizontal resistive tracks intersect can be used to map out the damage as shown in Figure 1c.

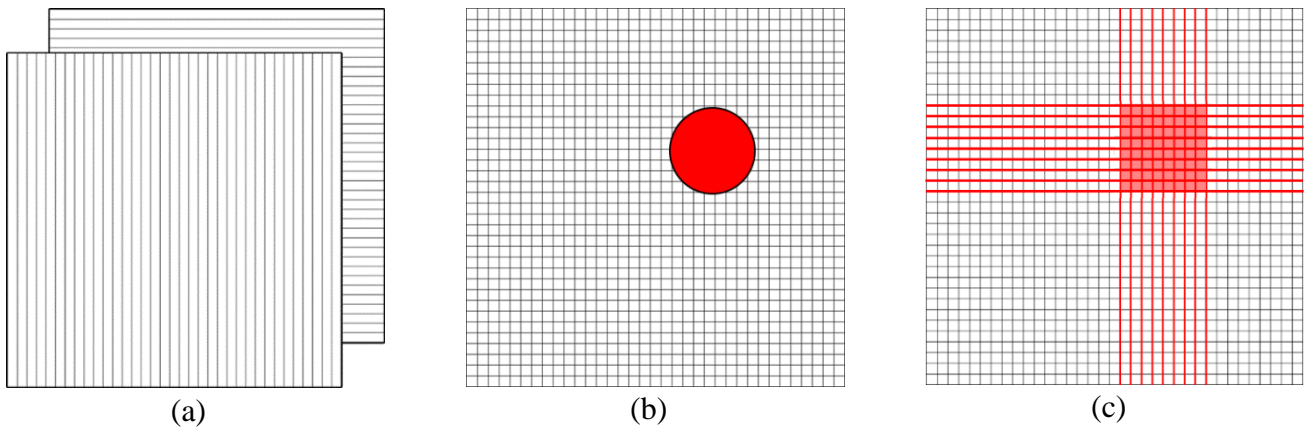

Figure 1. (a) A mesh with two layers: one with vertical resistive tracks and another one with horizontal resistive tracks; (b) an example of the penetrating damage caused in the smart material; (c) the affected resistive circuits on the two layers and the mapped damaged area resulting from the intersecting tracks.

One limitation that can be observed from that example is that the detected region has a rectangular shape and this might not be representative of the actual shape of the damaged area. To improve the shape of the detected region, more layers can be added (with their resistive tracks put in different orientations). Adding more layers would also increase the accuracy when multiple impacts occur. Consider the example in Figure 2a, where a second impact is introduced to the previously damaged surface. The blue circle represents the newly damaged area. Since the damaged areas are detected according to where all broken resistive tracks intersect, then the sensor would erroneously detect four impacts as shown in Figure 2b. However, the areas highlighted in purple are undamaged and would thus be false positives. If in the future, damage occurs within these locations, this would remain undetected because the resistive were already broken.

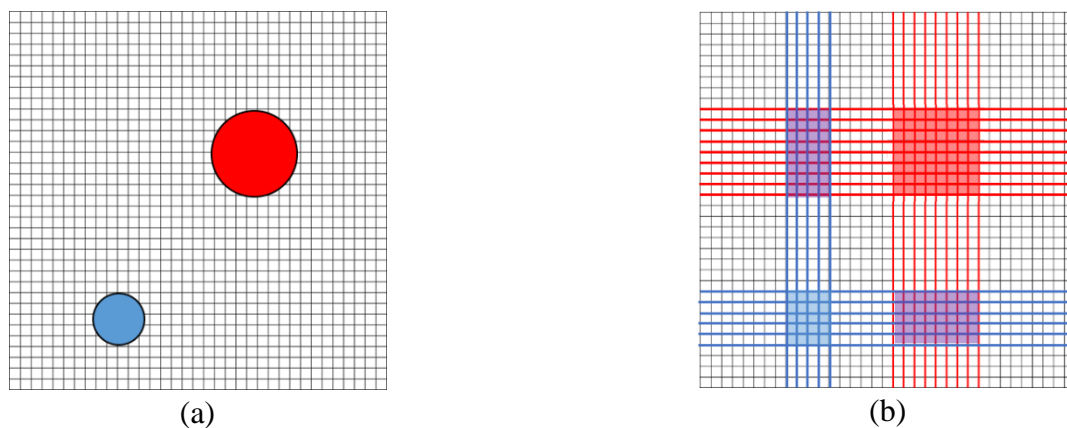

Figure 2. (a) A scenario with multiple impacts; (b) intersecting tracks highlighting the old damaged area in red, the new damaged area in blue and the two false positives in purple.

To address these two limitations, the smart surface was designed with four layers. The orientation of the resistive circuits in each layer are offset from by  $45^\circ$ . Considering the two impact points with a four-layer smart surface as shown in Figure 3a, the damaged area is identified by checking where the broken resistive tracks in all four layers intersect, as shown in Figure 3b. The damage is mapped more accurately as shown in Figure 3c. Due to the increased number of layers, no false positives were detected.

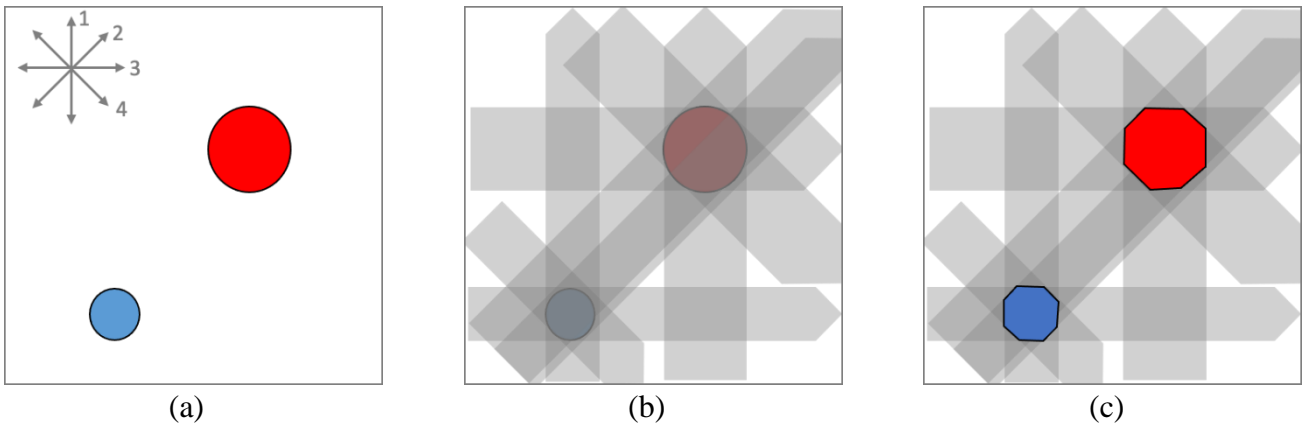

Figure 3. (a) A scenario with multiple impact on a four-layer sensor; (b) the intersection of the damaged tracks; (c) the mapped damaged areas from the intersecting tracks.

To determine whether a resistive track is broken or still intact, one end is connected to ground (i.e. the negative terminal of the power supply) while the other end is connected to the input of an embedded device. A pull-up resistor is connected between the input of the embedded device and the positive terminal of the power supply. A schematic with the connections of the resistive tracks is shown in Figure 4a. When the resistive track is broken, the voltage at the input becomes equal to that at the positive terminal of the power supply. For an embedded device with a digital input, this voltage appears as a logical high. Meanwhile, when the resistive track is still intact, the voltage at the input of the embedded device is equal to 0V (i.e. the voltage at the negative terminal of the power supply). For the embedded device, this voltage appears as a logical low. In its complete form, the mesh would have hundreds of fine resistive tracks. However, an embedded device would not have sufficient input pins for such a large grid. Therefore, multiplexers would have to be used. With a multiplexer, each resistive track would have an address and by changing the address inputted to the multiplexer the resistive tracks can be checked one at a time. A schematic of the circuit with the multiplexer is shown in Figure 4b.

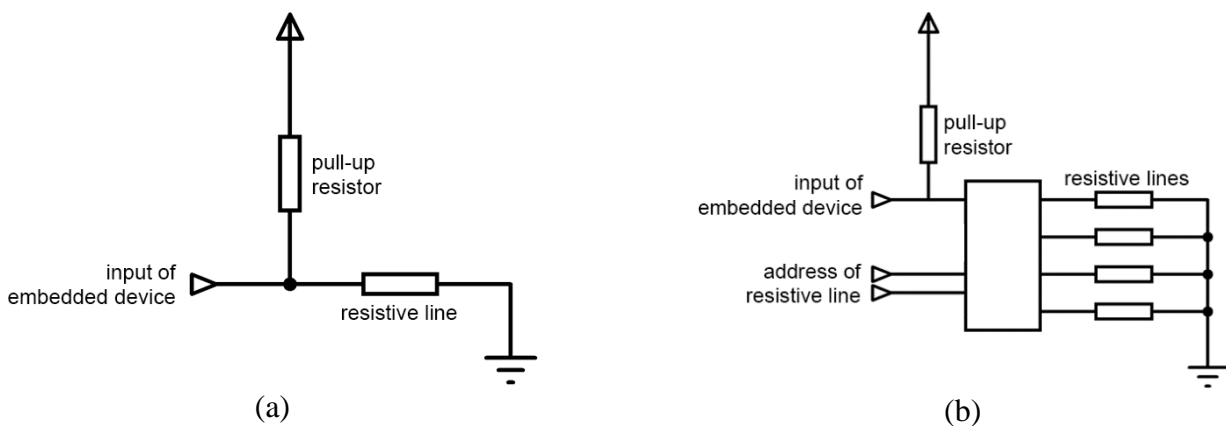

Figure 4. (a) Schematic with the connections of the resistive tracks, and (b) schematic of the circuit with the multiplexer.

The algorithm proposed for the embedded device represents the mesh using a two-dimensional matrix, where each element corresponds to an area on the mesh. The number of rows and columns of the matrix is equal to the number of resistive tracks in each layer. To detect and localise damage, the algorithm addresses each resistive circuit one by one and updates the matrix accordingly. Matrix elements whose corresponding areas are damaged are set to true while those whose corresponding areas are undamaged are set to false.

By De Morgan's Law, there are two ways how the matrix can be updated: set an element to true only if all resistive tracks passing through the corresponding point are broken, or set an element to false only if there is at least one resistive track passing through the corresponding point that is still intact. In this work, the latter approach was taken. The matrix elements are initially set to true. Then, the proposed algorithm iterates for each resistive track address. When the algorithm reads a logical low, the resistive track is considered to be still intact and thus it sets the elements of the corresponding line in the matrix to false. When it reads a logical high, the algorithm considers the resistive track to be broken, and no updates take place. The resultant matrix after going through all of the addresses is a map of the damaged areas.

Following the conceptual design of the impact sensor, a prototype was designed and developed. Experiments were carried out to evaluate the prototype, as described in the following section.

### 3 DESIGN OF EXPERIMENT

A 4-layer PCB was manufactured with the design shown in Figure 5. Each layer was designed with 16 resistive tracks, thus the mesh had a total of 64 resistive tracks. To simplify manufacturing, the widths of the resistive tracks was set to 2mm. The spacing between the resistive tracks was also set to 2mm.

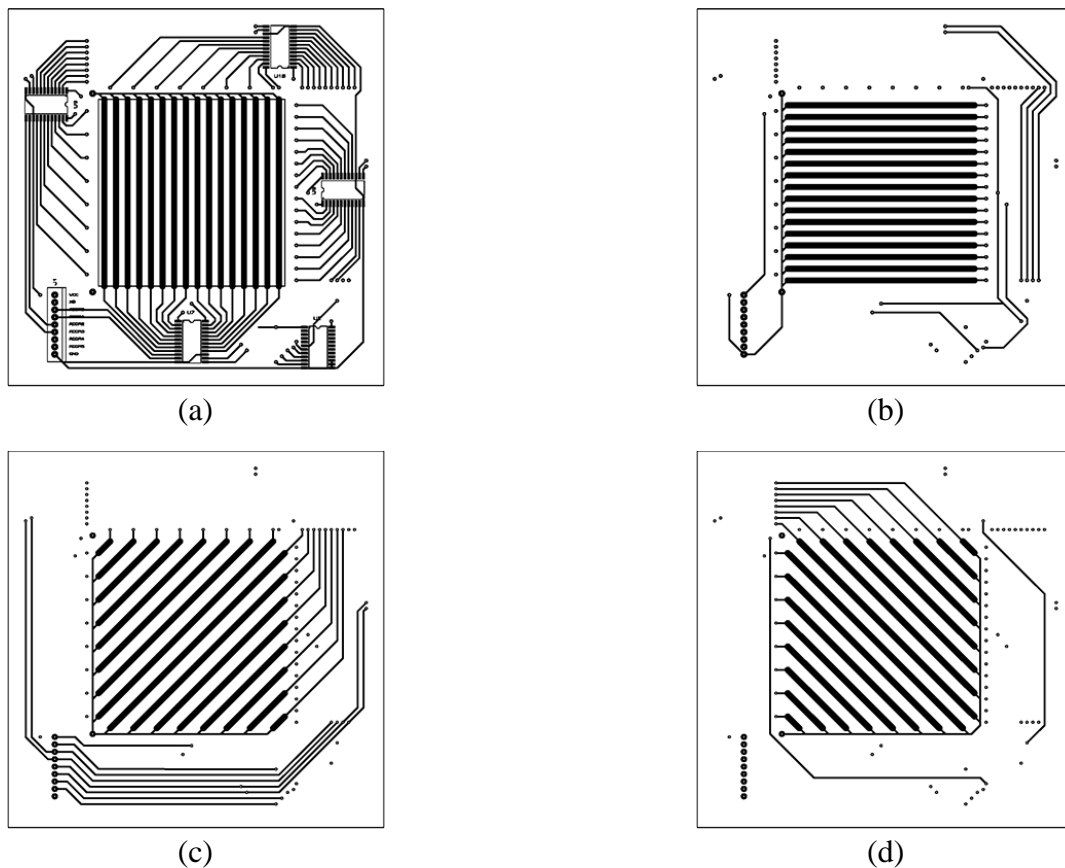

Figure 5. The (a) top, (b) bottom, (c) inner 1, and (d) inner 2 layers of the developed PCB

During the experiments, the expected damage caused by hypervelocity impacts on satellite shields was simulated by drilling a number of holes into the PCB. While this does not replicate the phenomena taking place in the material during hypervelocity impacts, it was deemed sufficient to assess the concept. Two experiments were carried out. The first experiment evaluated the performance of the proposed concept in determining the size and shape of a damaged area. This was

conducted by drilling concentric holes on the PCB as shown in Figure 6. The diameters of the holes were 6mm, 12mm, 18mm, and 24mm respectively. After performing each hole, the matrix with the damaged locations that is produced by the proposed algorithm was recorded.

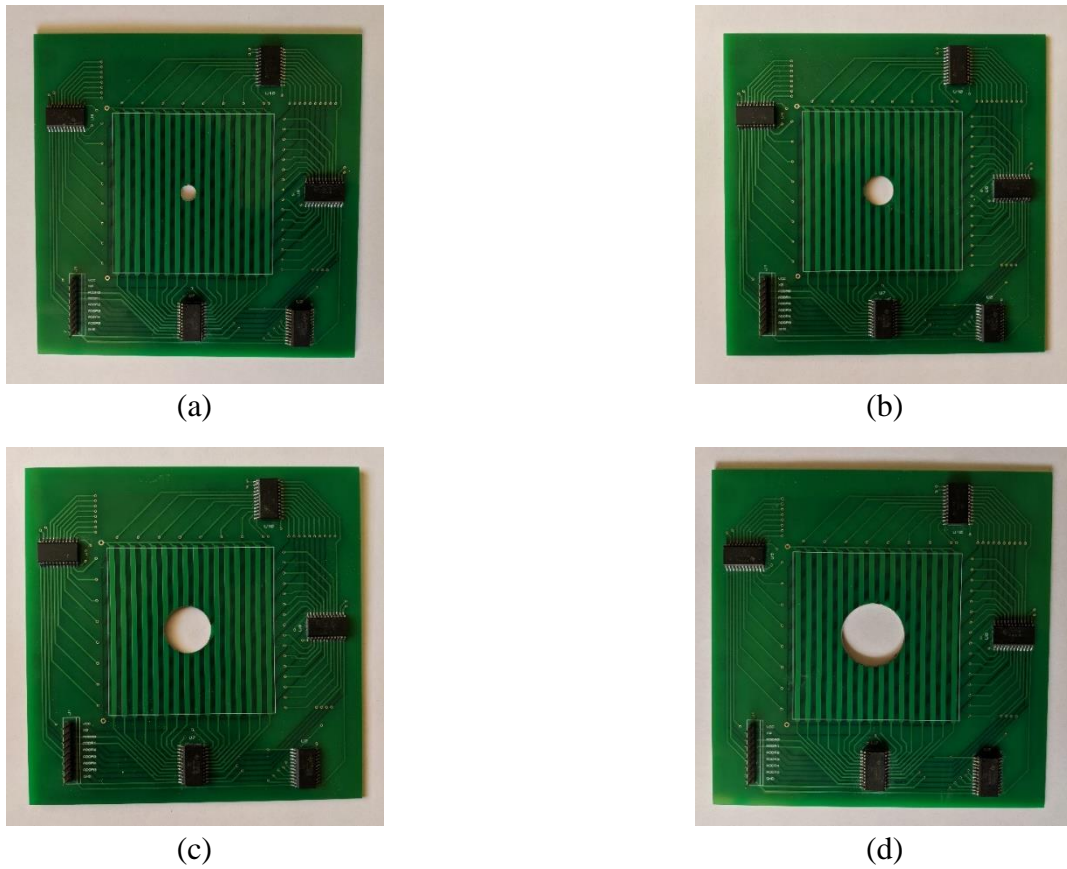

Figure 6. Experiment with (a) 6mm, (b) 12mm, (c) 18mm, and (d) 24mm concentric holes.

The second experiment evaluated the performance of the proposed concept in detecting and locating damage from multiple impacts. Holes were drilled at different locations of an identical PCB as shown in Figure 7. The first hole with a diameter of 5mm was drilled at the bottom-right corner of the PCB. The second hole with a diameter of 10mm was added to the top-right corner of the PCB. The third hole with a diameter of 10mm was added to the bottom-left corner of the PCB. As was done in the previous experiment, after drilling each hole, the matrix with the damaged locations that is produced by the proposed algorithm was recorded. These were then mapped into an image with the results presented in the following section.

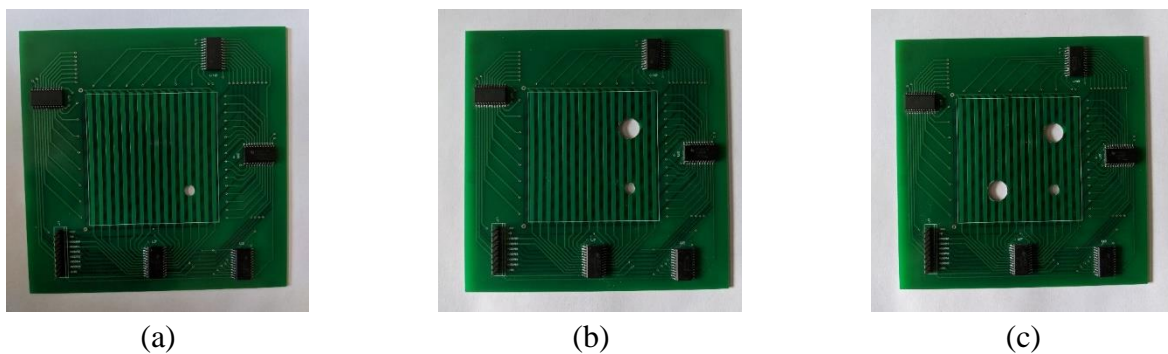

Figure 7. (a) 5mm hole introduced to the PCB; (b) 10mm hole added to the top right of the resistive grid; (c) 10mm hole added to the bottom left of the grid.

## 4 RESULTS

The results of the first experiment are shown in Figure 8. The detected damaged areas are marked in black. It can be immediately observed that as the hole was enlarged, the size of the detected damage increased as well. Figure 8a shows that the 6mm hole was detected as a square with sides of 4mm. The inaccuracies in the detected size and shape were caused by the fact that the hole was small in comparison to the widths and spacing of the resistive tracks. Since the widths and spacing of the resistive tracks were 2mm, the resolution of the mesh was 4mm. In Figure 8b, the 12mm hole is presented as a rectangle with sides 12mm and 8mm. The reason why the width and height of the detected area were different is that for damage to be detected, the resistive tracks have to be fully broken. In this case, the resistive tracks at the circumference of the hole that were only partially broken, and these appeared as if they were still intact. In this prototype, the width and spacing of the resistive tracks are relatively high, therefore limiting the resolution of the sensor. Due to this limitation, the detected region was found to be dependent on the position of the damage with respect to the resistive tracks. In Figure 8c, it can also be observed that as the diameter of the hole was increased from 12mm to 18mm, the shape of the detected area did not remain a quadrilateral, but lost two of its corners to better resemble that of a circle in low resolution. The width and height of this shape were both 16mm. Figure 8d shows the area detected when the hole was enlarged to 24mm. A similar effect occurred with the shape having an overall width of 20mm and a height was 24mm.

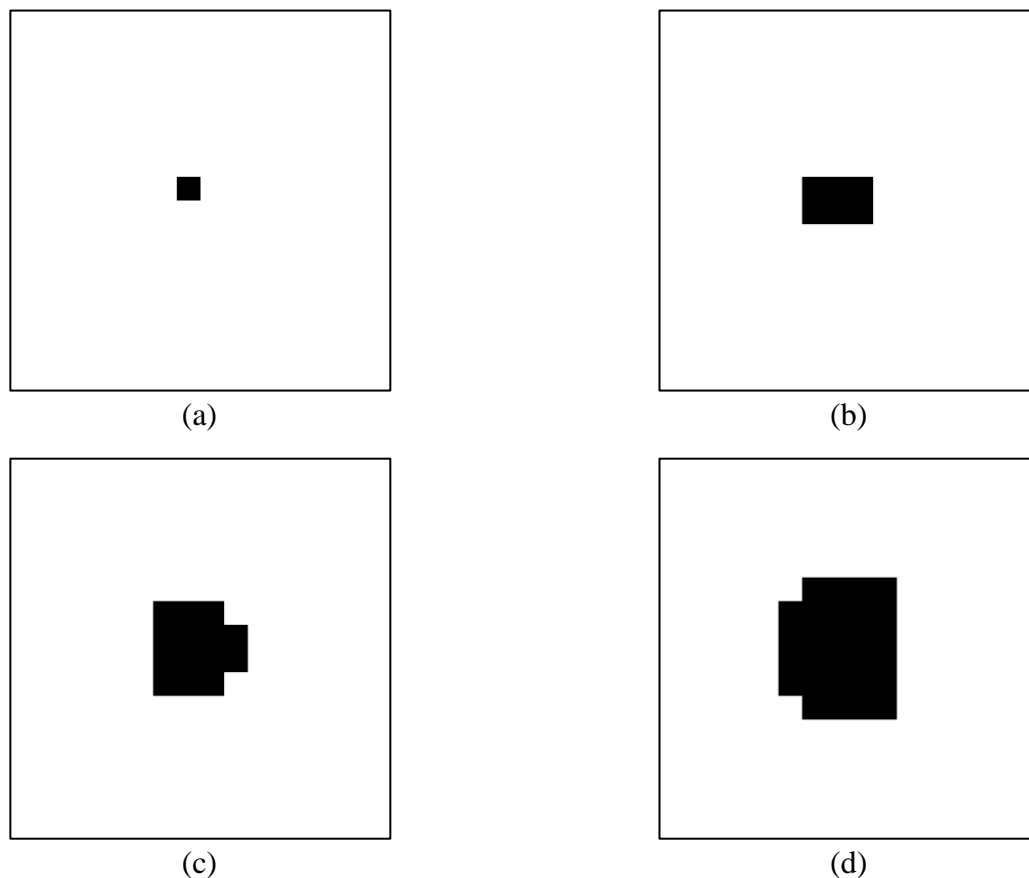

Figure 8. Results of the first experiment with the presence of (a) 6mm, (b) 12mm, (c) 18mm, and (d) 24mm holes

The results of the second experiment are shown in Figure 10. It can be shown that the damaged areas were all detected. In Figure 10a, the 5 mm hole was detected as a 4mm square. In Figure 10b, it can be shown that the 10 mm hole that was introduced in the top right corner was detected and mapped with a shape of 12 mm width and 8 mm height. In Figure 10c, the 10 mm hole introduced in the bottom left corner of the grid was detected and mapped with an 8 mm box. However, it can also be observed that as this second and third holes were introduced, the size and shape mapped for the first hole changed. The second and third holes shared vertical and horizontal layers respectively with the first hole. Therefore, out of four layers, only two layers with the diagonal resistive tracks were providing useful information for the determination of the size and shape of the damage for the first hole at the bottom-right corner. This reduction in information lowered the accuracy of the determined size and shape of the damaged area.

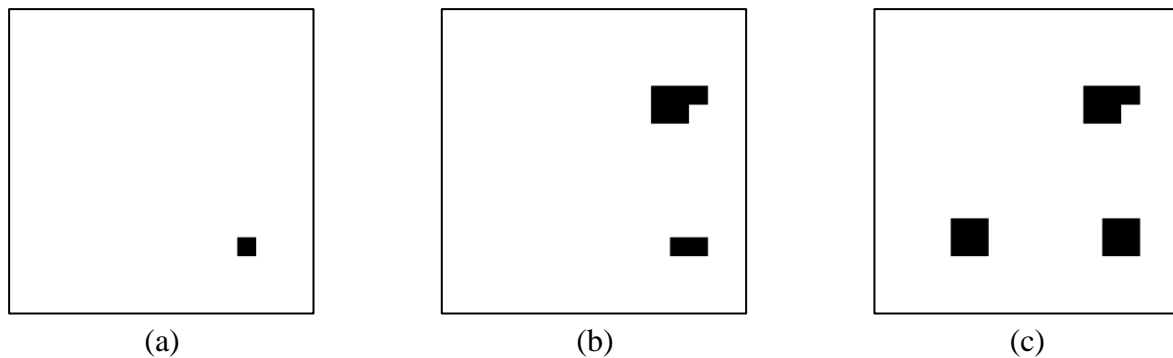

Figure 10. Results of the second experiment (a) 5mm hole introduced to the PCB; (b) 10mm hole added to the top right of the resistive grid; (c) 10mm hole added to the bottom left of the grid.

## 5 CONCLUSION AND FUTURE WORK

This paper presented a concept for developing a smart surface that detects damage from multiple hypervelocity impacts. The damaged locations are marked in a two-dimensional matrix, which was then used for determining the location, size and shape of the damage. The results show that the concept supports the detection of multiple damaged areas. However, the accuracy of the size and shape of the damaged regions is dependent on the resolution of the resistive mesh and the location of the damage with respect to the resistive tracks. An improvement in accuracy and resolution can be achieved if the resistive grid would be made finer with track widths and gaps equal to a fraction of a millimetre. This will however also increase the complexity of the design due to the increased multiplexers and computational effort required to map the damaged area. In the future, the experiment could also be repeated in the environment of the application, using a light gas gun to replicate damage on the smart surface, thus raising the TRL of the sensor.



## 6 REFERENCES

- [1] Satellite launches to increase threefold over the next decade [online], <https://www.satellitetoday.com/innovation/2017/10/12/satellite-launches-increase-threefold-next-decade/>, Accessed on 18/05/18
- [2] Gruntman, M., “Passive optical detection of submillimeter and millimeter size space debris in low earth orbit,” *Acta Astronautica*, Vol. 105, No. 1, pp. 156-170, 2014.
- [3] “Factsheet,” USSTRATCOM Space Control and Space Surveillance, [Online]. Available: [http://www.stratcom.mil/factsheets/USSTRATCOM\\_Space\\_Contro](http://www.stratcom.mil/factsheets/USSTRATCOM_Space_Contro). [Accessed 23 12 2013].
- [4] Kessler, D. J., and Cour-Palais, B. G., “Collision frequency of artificial satellites: The creation of a debris belt,” *Journal of Geophysical Research: Space Physics*, vol. 83, no. A6, pp. 2637-2646, 1978.
- [5] Francesconi, A., Giacomuzzo, C., Barilaro, L., Segato, E., Sansone, F.: *Experimental Study of Spacecraft Material Ejected upon Hypervelocity Impact, Hypervelocity Impacts & Shielding*, Sixth European Conference on Space Debris, Darmstadt (Germany), April 2013
- [6] Olivieri, L., Giacomuzzo, C., Francesconi, A., Stokesd, H., and Rossi, A., “Experimental characterization of multi-layer 3D-printed shields for microsattellites,” *Journal of Space Safety Engineering*, vol. 7, no. 2, pp. 125-136, 2020.
- [7] Rossi, A., Alessi, E. M., Schettino, G., Beck, J., Holbrough, I., Schleutker, T., and Gerardin, S., “The H2020 ReDSHIFT project: a successful European effort towards space debris mitigation”.
- [8] Barilaro, L., Falsetti, C., L.Olivieri, C.Giacomuzzo, Francesconi, A., Beard, P., and Camilleri, R., “A conceptual study to characterize properties of space debris from hypervelocity impacts through Thin Film Heat Flux Gauges,” *2021 IEEE 8th International Workshop on Metrology for AeroSpace (MetroAeroSpace)*, Naples, Italy, 2021.
- [9] J. Hamilton, J. L., Anz-meador, P., Corsaro, B., Giovane, F., Matney, M., and Christiansen, E., “Development of the Space Debris Sensor,” *Proceedings of the 7th European Conference on Space Debris*, Darmstadt, Germany, 2017.