Session 2: Hayabusa2

Hayabusa2's kinetic impactor

Takanao SAIKI (JAXA)

**Hiroshi Imamura, Hirotaka Sawada, Kazunori Ogawa, Yuya Mimasu,
Yuto Takei, Masahiko Arakawa, Toshirhiko Kadono, Koji Wada,
Atsushi Fujii, Fuyuto Terui, Naoko Ogawa, Go Ono, Kent Yoshikawa,
Makoto Yoshikawa, Satoru Nakazawa, Yuichi Tsuda**

***7th IAA Planetary Defense Conference
26-30 April 2021***

Impact experiment of Hayabusa2



■ Sub-surface exploration

- ◆ A surface investigation alone is not sufficient.
 - Asteroid surface is altered by cosmic rays, solar wind particles, ...
- ◆ Investigating the internal structure and sampling “fresh” underground materials were required to learn about the evolution of asteroids and our solar system.
- ◆ Investigating asteroid’s structure is important for the planetary defense.

■ Artificial crater generation via kinetic impact.

- ◆ Small body impact missions: Deep Impact / DART
 - Large impactor spacecraft.
 - Huge impact energy.
 - A 300 kg-class impactor spacecraft was studied in the early concept study phase.
-> not realized due to the financial circumstances.
- ◆ JAXA developed a new low-cost small impact system.
 - Small Carry-on Impactor (SCI)



Small Carry-on Impactor



■ SCI: Small Carry-on Impactor

- ◆ Small kinetic impact device (Space cannon, bomb)
 - It was mounted on the bottom panel of Hayabusa2.
 - ◆ SCI was used after rendezvous with Ryugu.
 - It had to accelerate the impactor by itself.
 - ◆ Explosive propellant charge
 - 2 kg copper impactor.
 - Impact velocity: 2 km/s.
 - ◆ Very simple system
 - No GNC function.
 - Attitude: spin stabilization.
- > developed at low cost.

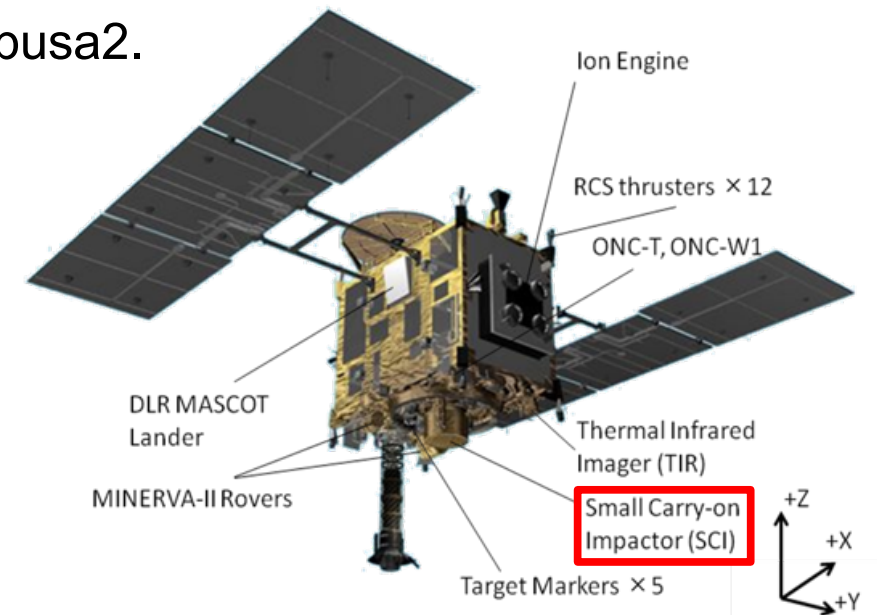

Configuration of SCI

Separation mechanism
(helical spring)

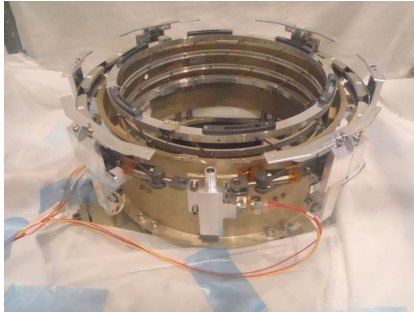

Total: 18kg
Separation mechanism: 4kg,
Main body: 14kg

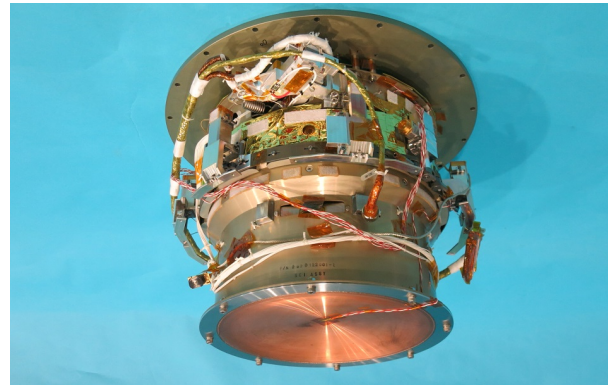

Safe & arm device
(Incl. detonator + booster)

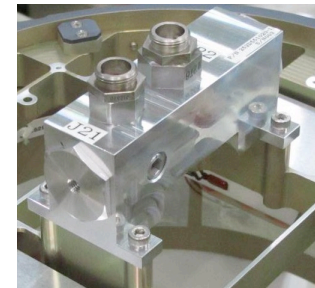

Main body



Electric device
(sequencer, ignition circuit)

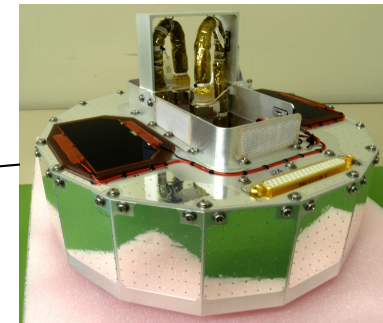

Shaped charge

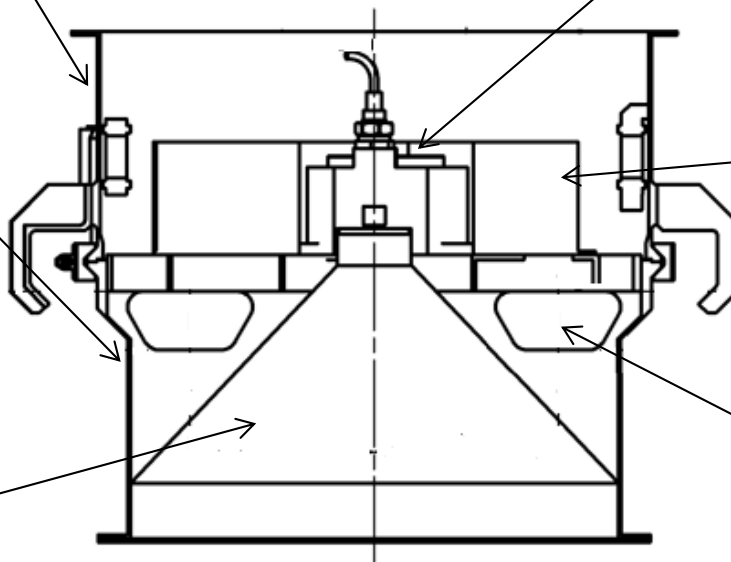
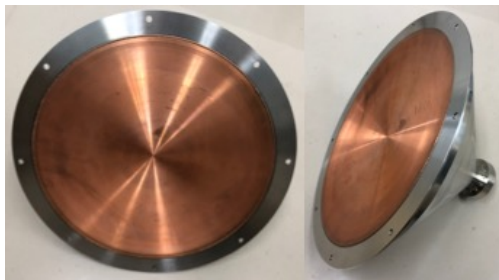

Primary battery

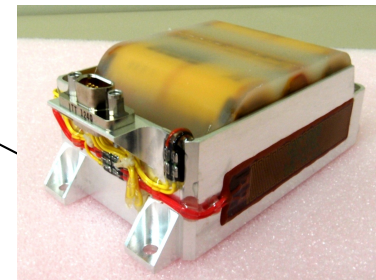

Shaped charge

- Weight: About 9.5 kg (Explosive: 4.7kg, Liner: 2.5kg)
 - Explosive: HMX-based plastic bonded explosive (PBX)
 - Acceleration time: Very short (less than 1 ms.)
 - Problem: The powerful explosive destroys the SCI main body and scatters many high-speed fragments.
- > Complicated operation.

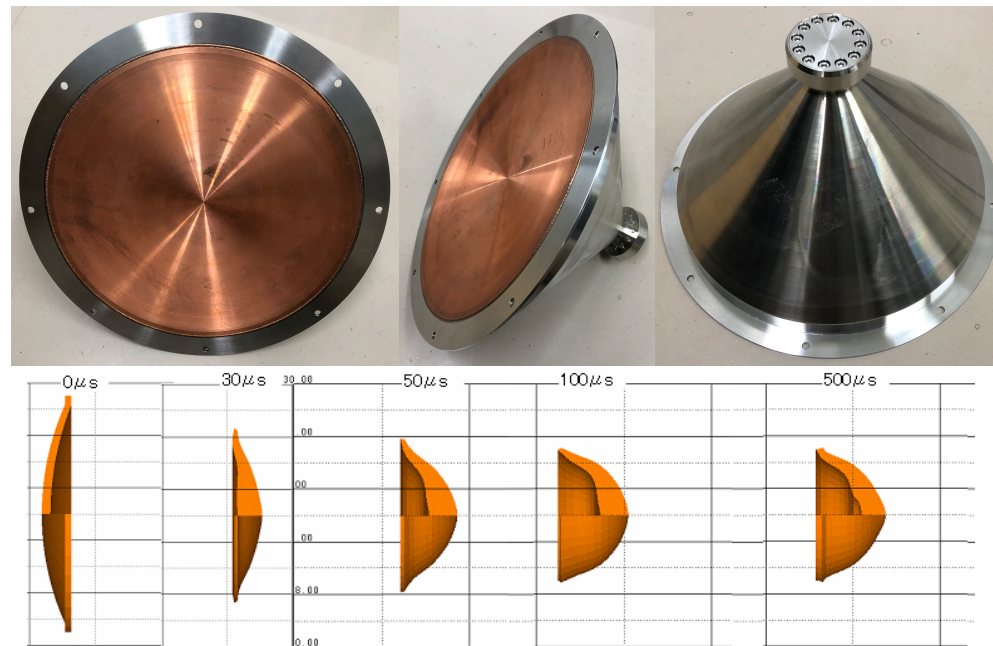
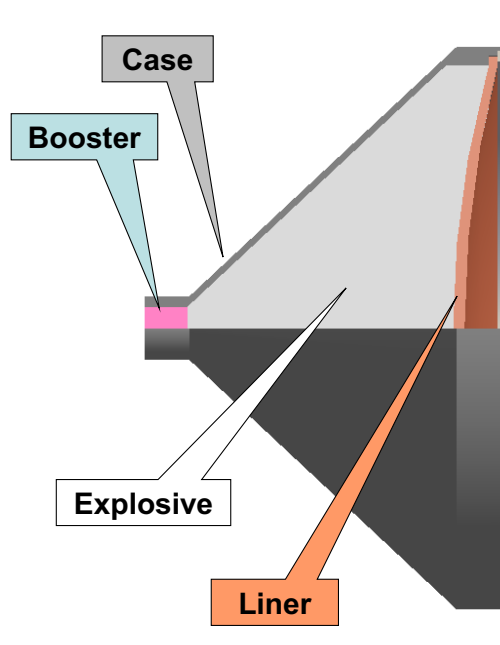

Impact operation sequence

- Escape maneuver
 - ◆ Hayabusa2 must escape to the safe zone behind Ryugu's limb to avoid the debris and ejecta.
- Sequence of impact operation
 1. SCI Separation. Alt: about 500m
 2. Horizontal maneuver.
 3. DCAM3 deployment.
 4. Vertical maneuver.
 5. Retreat into safe zone.
 6. SCI impact. (40 min after the SCI release).
 7. DCAM3 images acquisition

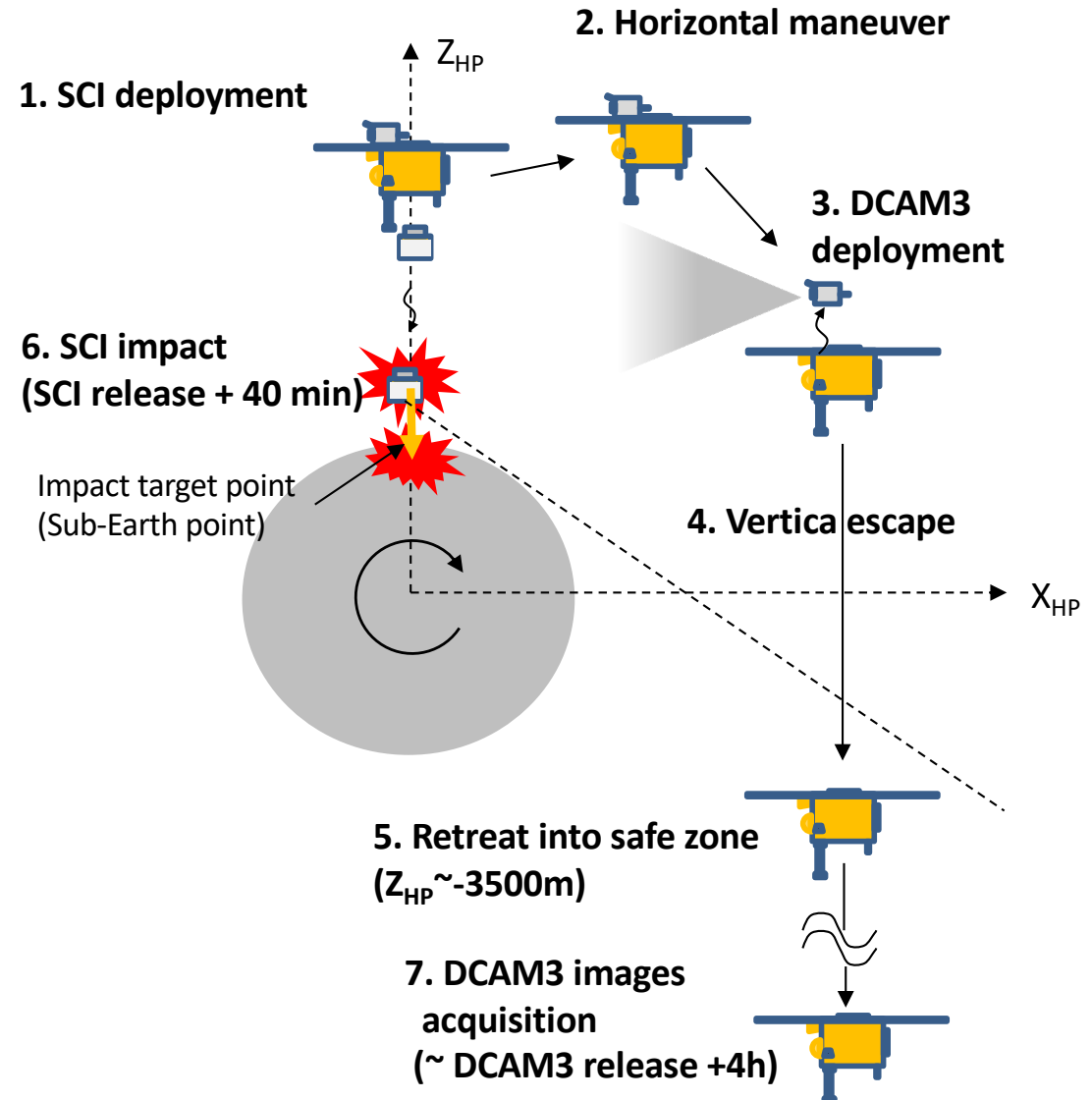
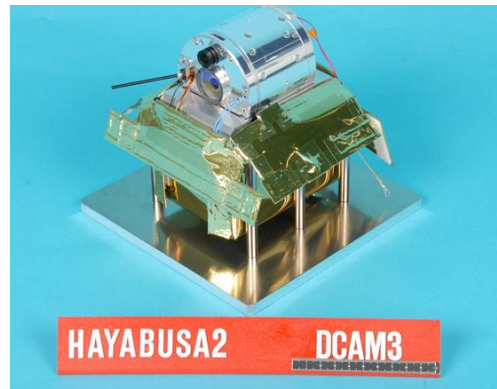

Impact Target

- Impact Target: Lat=6degN, Lon=303deg
 - ◆ On the equatorial ridge of Ryugu.
 - ◆ Near S01 area (Flat area found by the global survey)
- Impact epoch: 2:36:10 on April 5 2019.
 - ◆ SCI release: 40 min before the impact epoch.

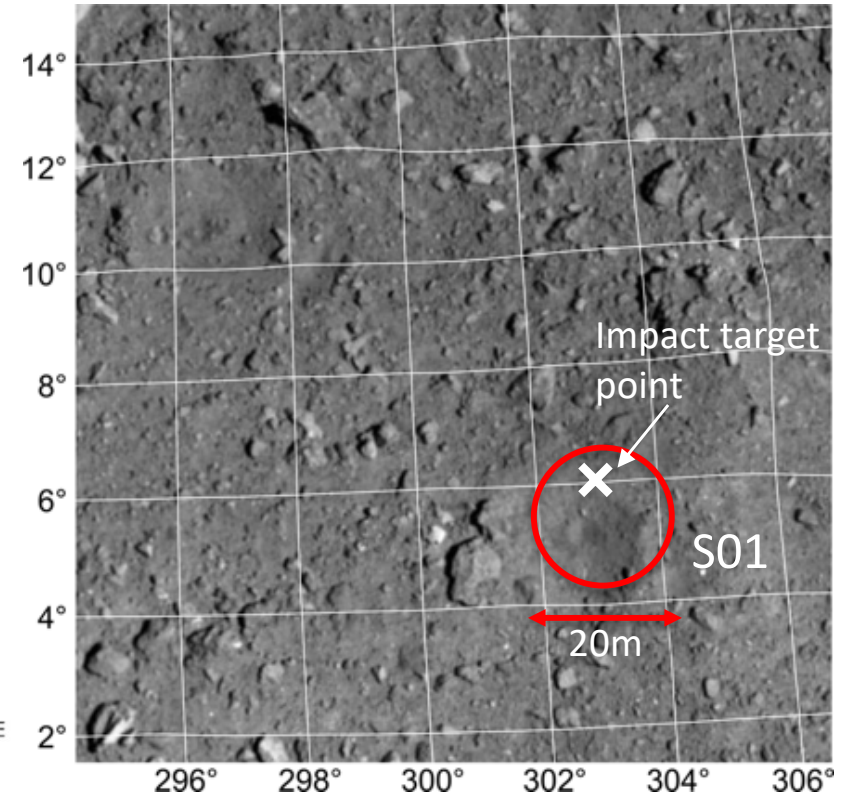
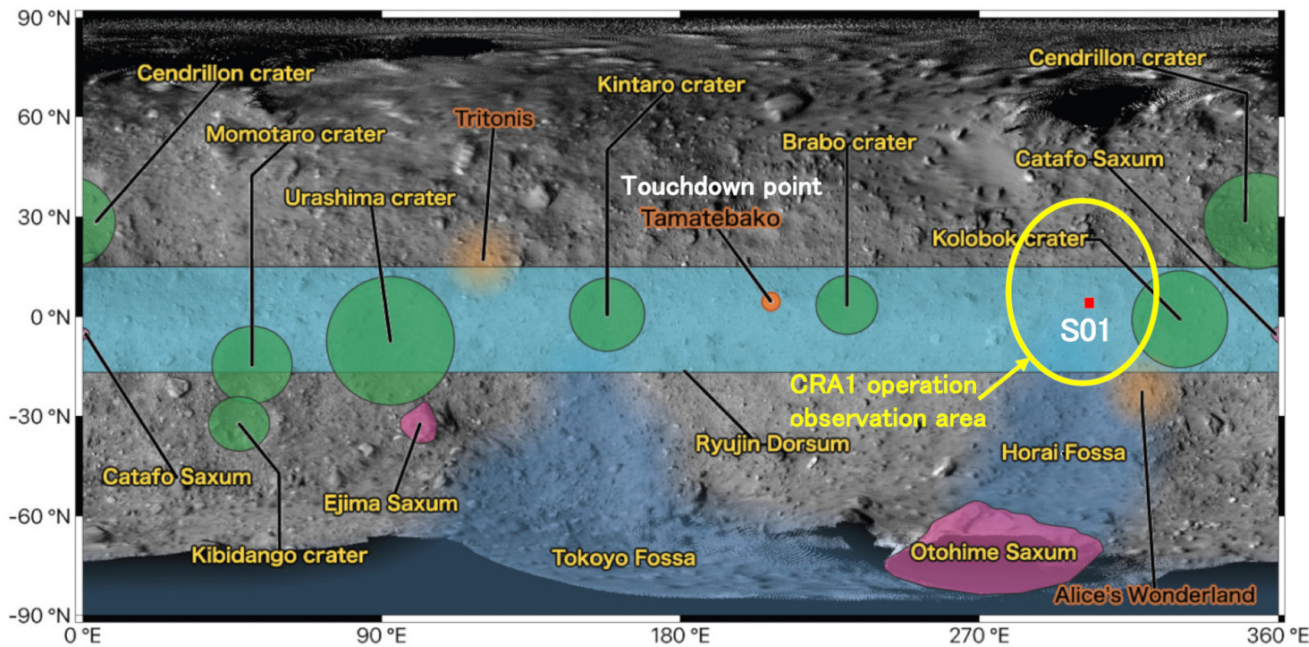

SCI impact experiment



■ Impact experiment: April 4-5, 2019

Time(UT)	Events
Apr. 4 04:00	Start descent (40cm/s, alt=20km)
Apr. 5 00:21	SCI ON
00:44	Begin GO/NOGO judgement
01:05	Send GO commands
01:44	Target altitude arrival & start hovering
01:52:20	+Z dV (final dV before SCI sep.)
01:56:11	SCI separation, alt=500m
01:57:37	+X dV (evacuation dV 1)
02:02:26	-Z dV (evacuation dV 2)
02:10:07	-X dV (evacuation dV 3)
02:14:25	DCAM3 separation
02:15:27	-Z dV (evacuation dV 4)
02:36:10	SCI explosion & impact !
07:22	Stop observation command to DCAM3

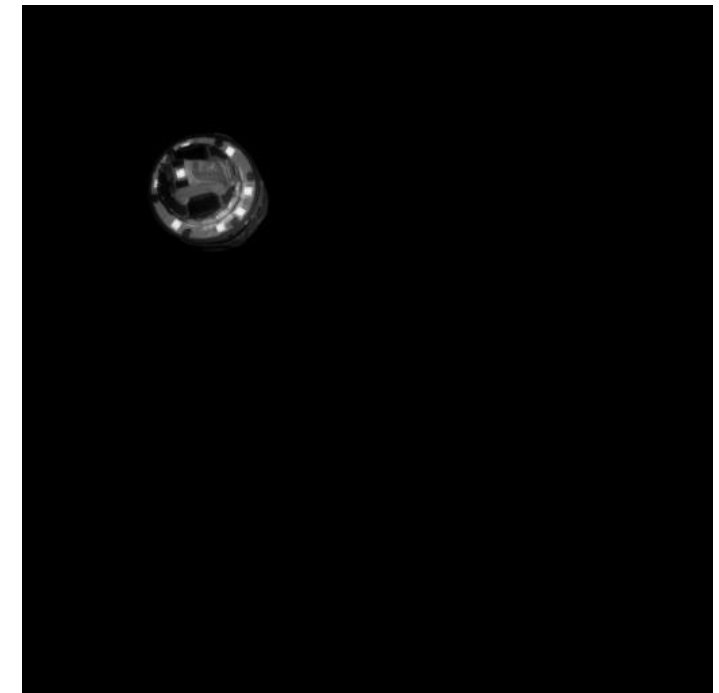

Released SCI (1:56:17)

DCAM3 images

■ Photos from DCAM3

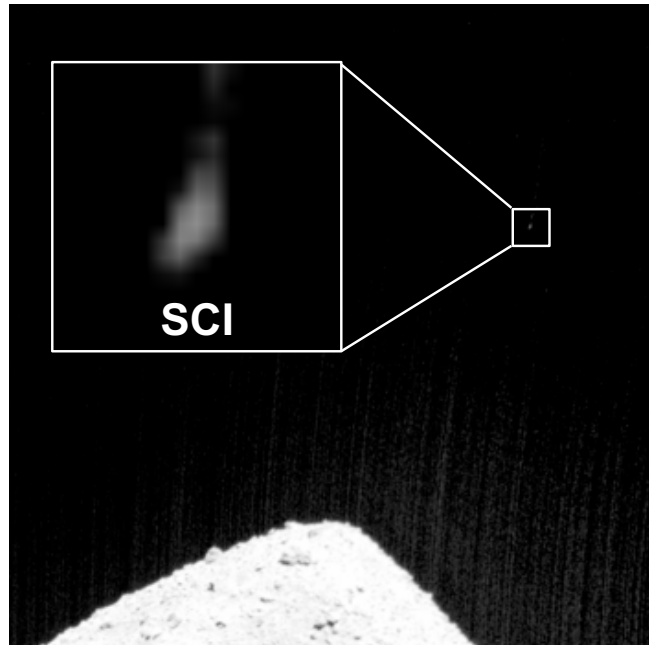

185sec before SCI ignition



2sec after the impact (analog camera)

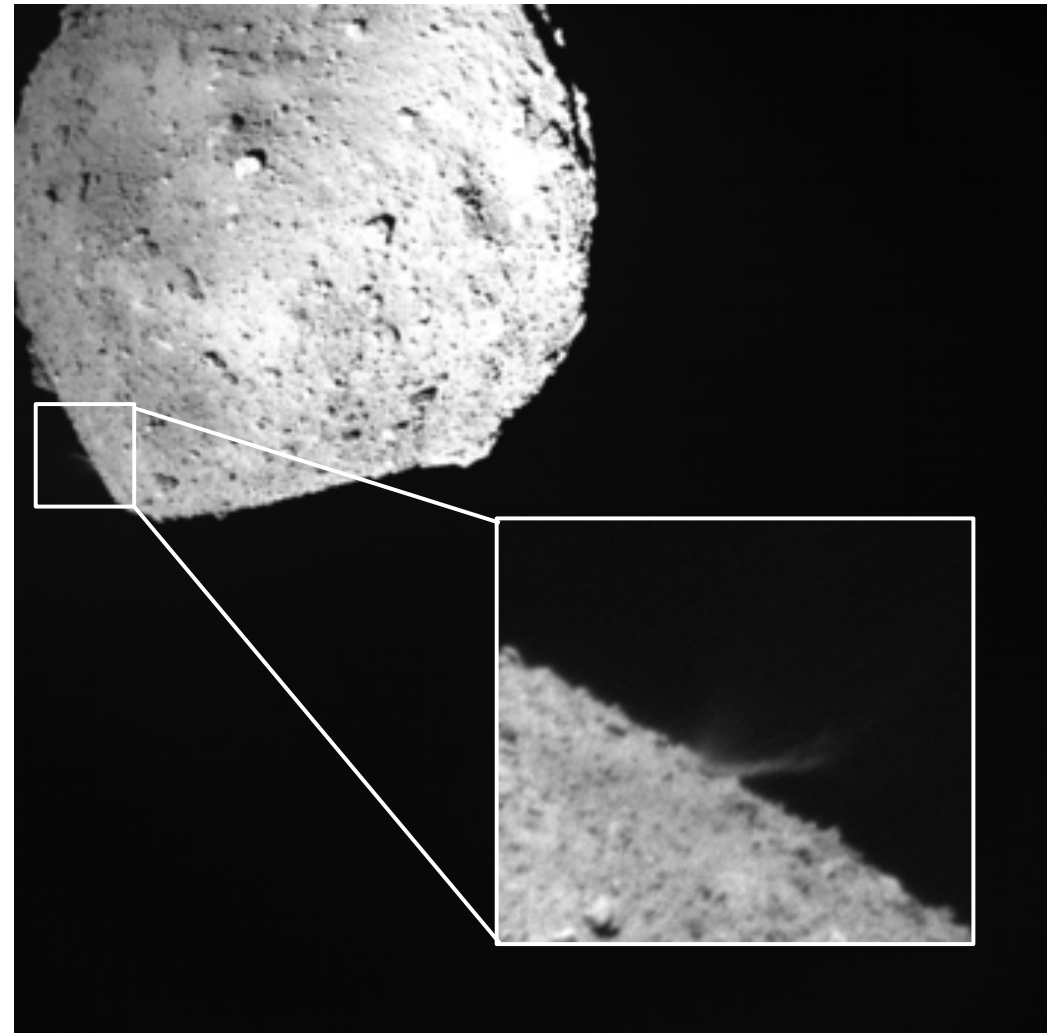

3sec after the impact (digital camera)

Artificial Crater

- 15m class crater
 - ◆ Impact position: only 20m off from the target !
 - > The SCI was released with small velocity & pointing errors.
- July 11, 2019: 2nd sampling (North of crater).

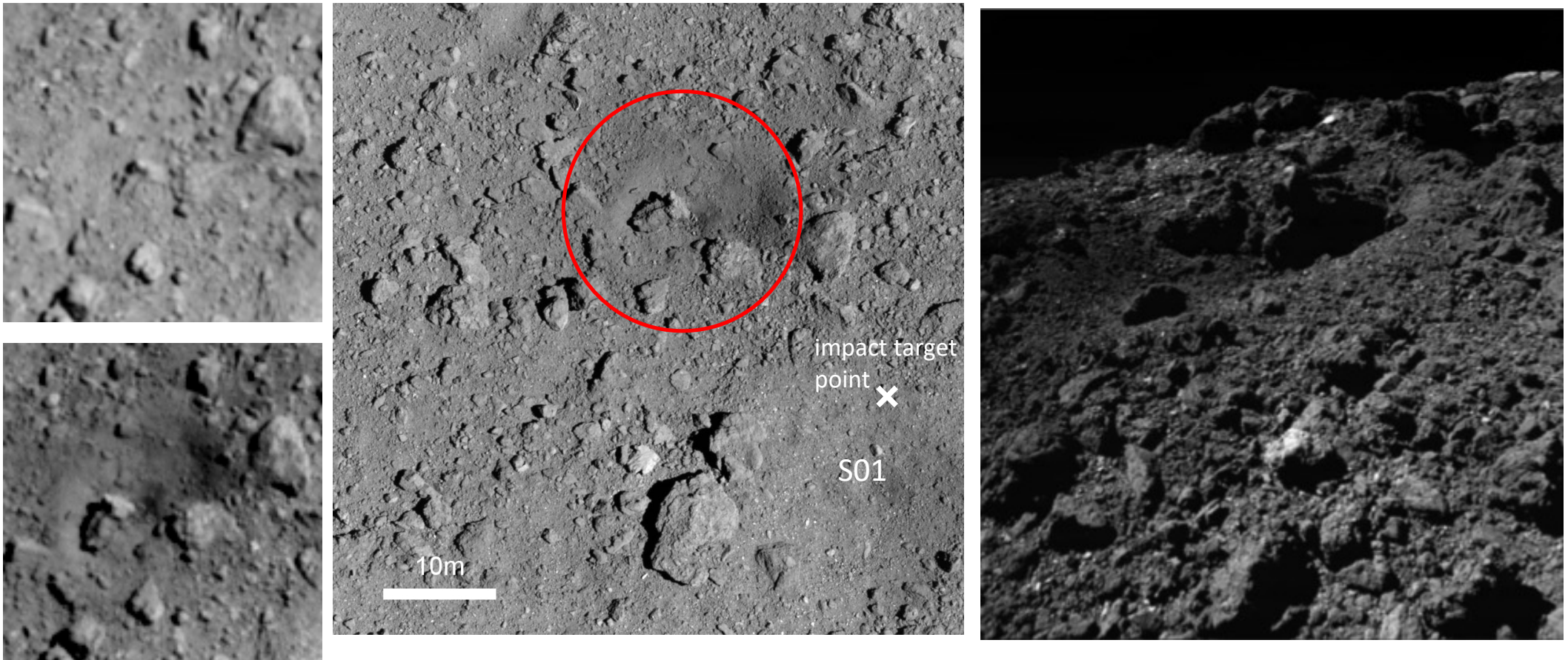

Summary



- The investigation of the sub-surface structure and materials was the new objective of Hayabusa2 that was not seen with Hayabusa.
- Hayabusa2 was equipped with a compact kinetic impactor (SCI) and a small deployable camera (DCAM3).
- The spacecraft, SCI, and DCAM3 worked perfectly in the impact experiment on April 5, 2019.
- A 15m-class artificial crater was created, and its formation process was observed by the DCAM3.
- Impact energy of the SCI is too small to deflect the asteroid.
- However, the SCI is an important tool for planetary defense because the artificial crater gives us valuable information about the structure of small bodies.