

7th IAA Planetary Defense Conference – PDC 2021
26-30 April 2021, Vienna, Austria

IAA-PDC-21-08-XX

**MASCOT ASTEROID NANOLANDERS: FROM RYUGU AND DIDYMOON
TOWARDS FUTURE MISSIONS AT ‘2021 PDC’, APOPHIS 2029, AND BEYOND**

**Caroline Lange⁽¹⁾, Tra-Mi Ho⁽¹⁾, Jan Thimo Grundmann^{(1)*}, Laura Borella⁽²⁾,
Suditi Chand⁽²⁾, Federico Cordero⁽³⁾, Sebastian Fexer⁽¹⁾, Christian D. Grimm⁽¹⁾,
Jeffrey Hendrikse⁽²⁾, David Herčík⁽⁴⁾, Alain Hérique⁽⁵⁾, Lars Kessler⁽⁶⁾, Martin
Laabs⁽⁷⁾, Michael Lange⁽⁸⁾, Roy Lichtenheldt⁽⁹⁾, Dirk Plettemeier⁽⁷⁾, Dominik
Quantius⁽¹⁾, Flaviane C. F. Venditti⁽¹⁰⁾, Anne K. Virkki⁽¹⁰⁾**

⁽¹⁾*DLR German Aerospace Center, Institute of Space Systems, Robert-Hooke-
Strasse 7, 28359 Bremen, Germany – Caroline.Lange@dlr.de*

**corresponding coauthor +49-(0)421-24420-1107, jan.grundmann@dlr.de*

⁽²⁾*Consultants to DLR Institute of Space Systems*

⁽³⁾*Telespazio-VEGA, Darmstadt, Germany*

⁽⁴⁾*Institute of Atmospheric Physics, Czech Academy of Sciences, Czech Republic*

⁽⁵⁾*Institut de Planétologie et d’Astrophysique de Grenoble (IPAG), Université
Grenoble Alpes, CS 40700, 38058 Grenoble Cédex 9*

⁽⁶⁾*Levity Space Systems, Faculty of Aerospace Engineering, FH Aachen University of
Applied Sciences, Aachener-und-Münchener Allee 1, 52074 Aachen, Germany*

⁽⁷⁾*Dresden University of Technology, Chair for RF Engineering, Dresden, Germany*

⁽⁸⁾*DLR German Aerospace Center, Institute Composite Structures and Adaptive
Systems, 38108 Braunschweig, Germany*

⁽⁹⁾*DLR German Aerospace Center, Robotics and Mechatronics Center, 82234
Weßling, Germany*

⁽¹⁰⁾*Arecibo Observatory, HC3 Box 53995, Arecibo, PR 00612, USA*

Keywords: *MASCOT2, planetary science radar, Near-Earth Object, nanolander, re-use strategies*

ABSTRACT

For now, the Planetary Defense Conference *Exercise 2021*’s incoming *fictitious(!)* asteroid, 2021 PDC, seems headed for impact on October 20th, 2021, exactly 6 months after its discovery. Today (Monday, April 26th, 2021), the impact probability is 5%, in a steep rise from 1 in 2500 upon discovery six days ago. We all know how these things end. Or do we? Unless somebody wants to keep civil defense very busy very soon, the chance is 95% that it will *not* hit; instead fly by closely to Earth, swing by to a new orbit that takes it away essentially forever or back again sooner or later through a keyhole, for a re-play at different odds. This is where our story starts and the story sounds familiar: season’s greetings from 2004 MN₄, now better known as (99942) Apophis. One more thing is similar: the close fly-by is an easy launch opportunity to ‘jump aboard’ that potentially hazardous asteroid for planetary science and tracking of longterm Yarkovsky-shifted keyhole resonant return risks. Indeed, missions are currently being discussed to launch during the 2029 fly-by of Apophis to rendezvous and investigate it closely right after. Others strive for an earlier launch to rendezvous well before, to observe all of the close fly-by at Earth and what it might do to a likely delicate rubble pile asteroid. Presently, this is an unlikely if not impossible option for

sudden encounters like 2021 PDC with a lead time of months. But *when* asteroid mining (...possibly the other ...-not-if of asteroids?) takes off in the same manner as low Earth orbit communications satellites, this option may become a reality. But for now, even if a suitable planetary mission were serendipitously ready atop a suitable launch vehicle, could you get it an asteroid lander within 6 months? Surprisingly, this option existed between late 2014 and late 2018 when the MASCOT Qualification Model turned Flight Spare was kept fully integrated and flight ready for on-ground testing to prepare for the Flight Model's brief but complete mission on Ryugu with JAXA's highly successful HAYABUSA2 probe. At the same time, the MASCOT2 detailed design study for ESA's former AIM mission within the common NASA-ESA AIDA mission to (65803) Didymos and its moonlet, Dimorphos (then affectionately known as 'Didymoon'), paved the way for long-life MASCOTs, many of which have been discussed and studied since. The thoughtful design of MASCOT's hardware and software allowed for a very high degree of re-use and flexibility regarding scientific payloads. MASCOT2 was to investigate the interior of Didymoon by Low-Frequency Radar. Close encounters like Apophis' offer unique opportunities for Earth-based planetary radar assets to work with spacecraft near and landers on the passing asteroid. We present a range of options for radar- and composition-oriented long-life MASCOT variants – to be delivered to the surfaces of the respective asteroid bodies – for the presently most likely near miss of 2021 PDC and the most certain close fly-by of (99942) Apophis on Friday, April 13th, 2029.

INTRODUCTION

In a similarly brief event some 10½ years before Apophis' fly-by on Friday, April 13th, 2029, the Mobile Asteroid Surface Scout, MASCOT, successfully completed its 17-hour mission on the ~km-sized C-type potentially hazardous asteroid (162173) Ryugu. Investigating the surface and its thermal properties, looking for a magnetic field, and imaging the stark landscapes of this dark rubble pile, it contributed valuable close-up information before the surface sampling by its mothership, HAYABUSA2. [0][17]

Been running so fast: MASCOT

DLR in collaboration with the French space agency, CNES, has developed the Mobile Asteroid Surface Scout, MASCOT, a small asteroid lander which packs four full-scale science instruments and relocation capability into a shoebox-sized 10 kg spacecraft. [1] It carries the near-IR soil microscope, MicrOmega (MMEGA), [2] a high dynamic range black-and-white camera with night-time multicolour LED illumination (MasCAM), [3] a 6-channel thermal IR radiometer (MARA), [4] and a fluxgate magnetometer (MasMAG). [5]

MicrOmega is a near-infrared imaging spectrometer/microscope for the study of mineralogy and composition at grain scale. It acquires 3D (x,y,λ) microscopic image-cubes of an area approximately (3 mm)² in size with a spatial sampling of (25 μm)² in (128² pixel)² images. For each pixel, the spectrum is acquired in contiguous spectral channels covering the range 0.99 to 3.55 μm with spectral sampling better than 40 cm⁻¹ and a signal-to-noise ratio of 100, over the entire spectral range. [2]

MasCAM uses a clear filter 1 Mpixel Si-CMOS sensor with high dynamic range imaging capability covering a $(60^\circ)^2$ field of view, pointed slightly down to image an area in front of the lander. Multiple observations during the day are used for detailed studies of the reflection and scattering properties of the surface. During daytime, images are black-and-white. At night, colour images are taken using 4-channel IR-RGB LED illumination. [3]

MARA is a 6-band multispectral thermal infrared radiometer, covering wavelengths from 5 to 100 μm . In addition to a clear filter, the remaining channels are narrow-band filtered and can be adapted to a thermal infrared instrument aboard the orbiter. [4]

MasMAG is a vector compensated three-axis fluxgate magnetometer consisting of a digital electronics board and a sensor head. It has a long heritage from previous space missions. Due to the extreme conditions the design covered in these missions, the sensors can be mounted outside of the temperature controlled compartment. [5]

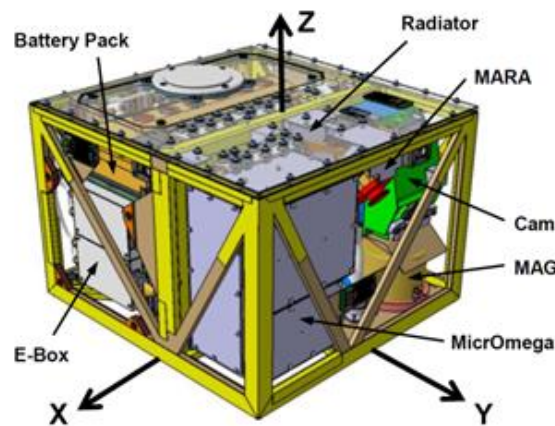

Fig.1 – The MASCOT Landing Module

Flight and Mission The MASCOT Flight Model (FM) was delivered to JAXA mid-June 2014 and was launched aboard the HAYABUSA2 space probe on December 3rd, 2014, to asteroid (162173) Ryugu. [0] MASCOT is an organically integrated high-density constraints-driven design. [1] The design, integration and testing of MASCOT followed a fast-paced Concurrent Assembly Integration Verification (C-AIV) approach. After preparatory studies, it was completed in 2 years from Preliminary Design Review (PDR) on June 6th, 2012 (the day of the Venus transit) to delivery of the Flight Model (FM) in July 2014 for integration and final joint testing with HAYABUSA2. [6][7][19]

Just remembered: MASCOT2 for AIM in AIDA

Closest to a follow-on came MASCOT2, developed for the AIM spacecraft which until 2016 was the partner mission of DART in the joint NASA-ESA AIDA mission to perform and study a kinetic impact on 'Didymoon', the moonlet of binary NEA (65803) Didymos. [8] MASCOT2 was a nanolander design to support the surface element of the bistatic low-frequency radar on AIM, LFR. [14][15] To support the LFR mission by context data and enable the transfer to its optimal operating location, as well as for observations of the DART impact within ~85 m of ground zero, MASCOT2 also

included MasCAM [3], MARA [4], the seismo-/accelerometer DACC, and had all resources reserved for MasMAG [5]. The MASCOT2 design was based on extensive re-use of MASCOT technologies but with tailored capability upgrades in the details of many subsystems. Changes were based as much on the different mission as on the lessons from MASCOT, by then already learned or at least anticipated due to the progress in MASCOT on-asteroid mission planning and the growing knowledge in the highly dynamic field of small solar system body science.

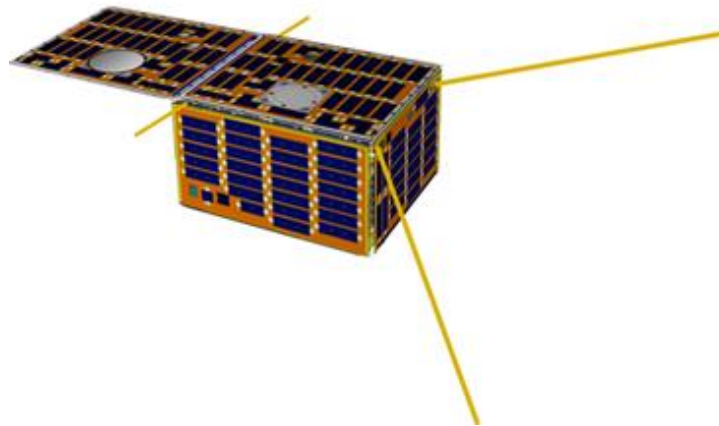

Fig. 2 - The MASCOT2 nanolander for AIM

Following the cancellation of MASCOT2 with AIM and the evaluation of nanolander requests and responses to other studies and proposals, the MASCOT team is currently pursuing maximum as-is re-use incarnations for future MASCOT nanolandings for near-term missions as well as designs more optimized in detail, similar in that respect to MASCOT2. Entirely new developments of the MASCOT concept are being studied, as well. [9]

ONE HAND'S JUST REACHING OUT: SMALL SPACECRAFT SYNERGIES

In particular for small interplanetary main spacecraft designed to fit the 'mini' and 'micro' rideshare payload slots on launch vehicles, resource-sharing concepts have been developed for MASCOTs based on technologies qualified in the GOSSAMER-1 solar sail deployment demonstrator project, itself a small 'micro' spacecraft composed of 5 independent 'nano' spacecraft. [10][11][16]

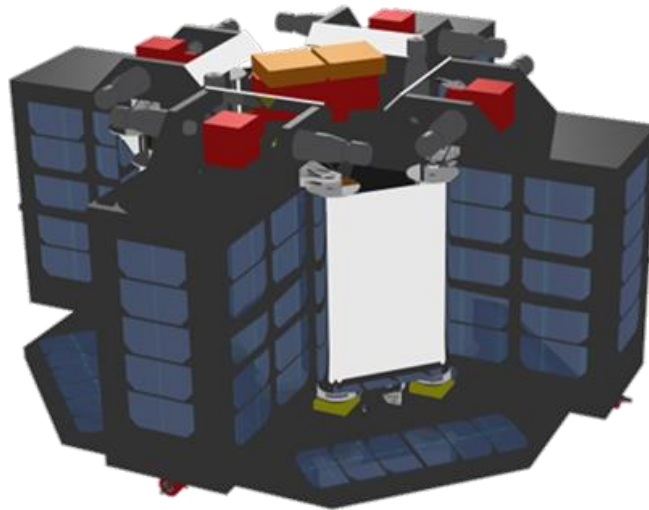

Fig.3 – Un pour tous, tous pour un – the shared resources multi-sub-spacecraft design of GOSSAMER-1

These concepts enable mutual support of a MASCOT nanolander and the small spacecraft carrying it during the cruise phase and until lander separation, for example power redistribution, shared batteries, more data handling and communication capabilities, and additional instruments and viewing angles.

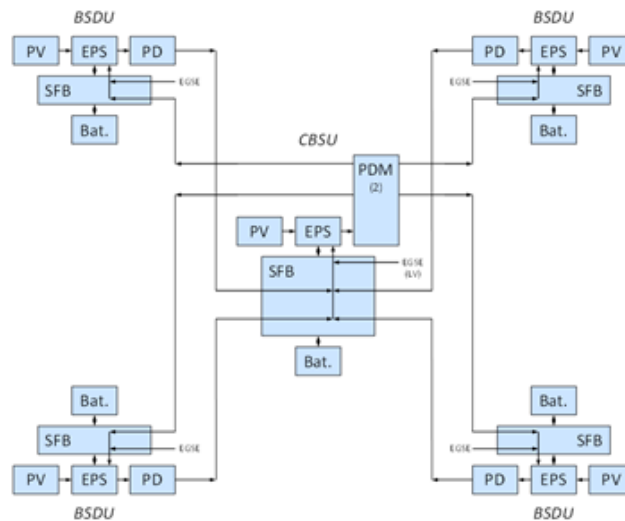

Fig. 4 - The GOSSAMER-1 Charging Network sharing all power resources of 5 nanospacecraft

Another feature of the Gossamer-1 system is a wireless communication network between all participating spacecraft. The communication system of HAYABUSA2 also shared this feature for optional parallel operation of the three MINERVA-II landers and MASCOT. [20] A more recent addition to the MASCOT portfolio are propulsion systems that enable self-transfer of the lander from a more distant carrier spacecraft. Together, these enable the operation of one lander by another spacecraft that did not carry it to its destination. [12][13][18]

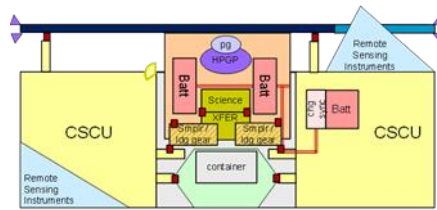

Fig.5 – Notional accommodation of a sample-return lander integrated organically with its carrier, here the Central Sailcraft Unit (CSCU) of an advanced solar sail of the GOSSAMER design concept.

CONCLUSION

From the portfolio of MASCOT follow-on studies, optimized designs of MASCOT@ApoPhis can be derived to address the needs of the many science missions proposed to rendezvous with Apophis. More than one MASCOT landing can be achieved by the end of the decade.

Acknowledgments

The authors acknowledge the work of the MASCOT, MASCOT2, GOSSAMER-1, GoSOLAR, and follow-on study teams and the support for these studies by the CEF team at DLR Bremen.

REFERENCES

- [0] T.-M. Ho et al., (2021), Planetary and Space Science, [DOI 10.1016/j.pss.2021.105200](https://doi.org/10.1016/j.pss.2021.105200) and references therein
- [1] T.-M. Ho et al., (2016) Sp.Sci.Rev., <https://doi.org/10.1007/s11214-016-0251-6>
- [2] J.-P. Bibring et al., (2017) Sp.Sci.Rev. 208, 401-412, <https://doi.org/10.1007/s11214-017-0335-y>
- [3] R. Jaumann et al., Sp.Sci.Rev. (2016), <https://doi.org/10.1007/s11214-016-0263-2>
- [4] M. Grott et al., Sp.Sci.Rev. (2016), <https://doi.org/10.1007/s11214-016-0272-1>
- [5] David Herčík et al., (2016) Sp.Sci.Rev., <https://doi.org/10.1007/s11214-016-0236-5>
- [6] Grimm et al., (2020) CEAS Space Journal, <https://doi.org/10.1007/s12567-020-00302-y>
- [7] Grimm et al., (2019) Progress in Aerospace Sciences 104 (2019) 20–39, <https://doi.org/10.1016/j.paerosci.2018.11.001>
- [8] C. Lange et al., (2018) Acta Astron., <https://doi.org/10.1016/j.actaastro.2018.05.013>
- [9] C. Lange et al., (2018) Adv. in Sp. Res., <https://doi.org/10.1016/j.asr.2018.05.013>
- [10] P. Seefeldt (2017), Adv. in Sp. Res. <https://doi.org/10.1016/j.asr.2017.06.006>
- [11] P. Seefeldt et al., Adv. in Sp. Res., <https://doi.org/10.1016/j.asr.2016.09.022>
- [12] S. Chand (2020) MASCOT Follow-on Mission Concept Study with Enhanced GNC and Propulsion Capability of the Nano-lander for Small Solar System Bodies (SSSB) Missions.

- [13] J.T. Grundmann et al., Acta Astr., <https://doi.org/10.1016/j.actaastro.2018.03.019>
- [14] A. Herique et al., Adv. In Sp. Res., <https://doi.org/10.1016/j.asr.2017.10.020>
- [15] A. Herique et al., Acta Astr., <https://doi.org/10.1016/j.actaastro.2018.03.058>
- [16] P. Spietz et al., Adv. in Sp. Res., [DOI 10.1016/j.asr.2021.01.044](https://doi.org/10.1016/j.asr.2021.01.044)
- [17] T.-M. Ho et al., Planetary Defense Ground Zero: MASCOT's View on the Rocks – an Update between First Images and Sample Return, IAA-PDC-21-06-YY (*this conference*)
- [18] M. Ceriotti et al., How we beat 2019 PDC to NYC by 2 years, within 2 years, 2 years ago, IAA-PDC-21-08-YY (*this conference*)
- [19] J.T. Grundmann et al., More Bucks for the Bang: New Space Solutions, Impact Tourism and one Unique Science & Engineering Opportunity at T-6 Months and Counting, IAA-PDC-21-08-YY (*this conference*)
- [20] C. Lange et al., (2020), Planetary and Space Science,, <https://doi.org/10.1016/j.pss.2020.105094>

~~~

**follow our progress during the PDC 2021 at our**

**[PublicFolder](#)**

[https://gla-my.sharepoint.com/:f:/g/personal/i\\_moore\\_3\\_research\\_gla\\_ac\\_uk/Eg-ISGBxoL1Lj9i89EGGYOABFNltvTiJ8df4PnLXHZkQ?e=sXL0L2](https://gla-my.sharepoint.com/:f:/g/personal/i_moore_3_research_gla_ac_uk/Eg-ISGBxoL1Lj9i89EGGYOABFNltvTiJ8df4PnLXHZkQ?e=sXL0L2)

~~~