

Asteroid deflection with IoT-inspired techniques

Dávid Farkas, László Baczárdi

Department of Networked Systems and Services, Budapest University of Technology and Economics (BME), Hungary
farkas96david@gmail.com

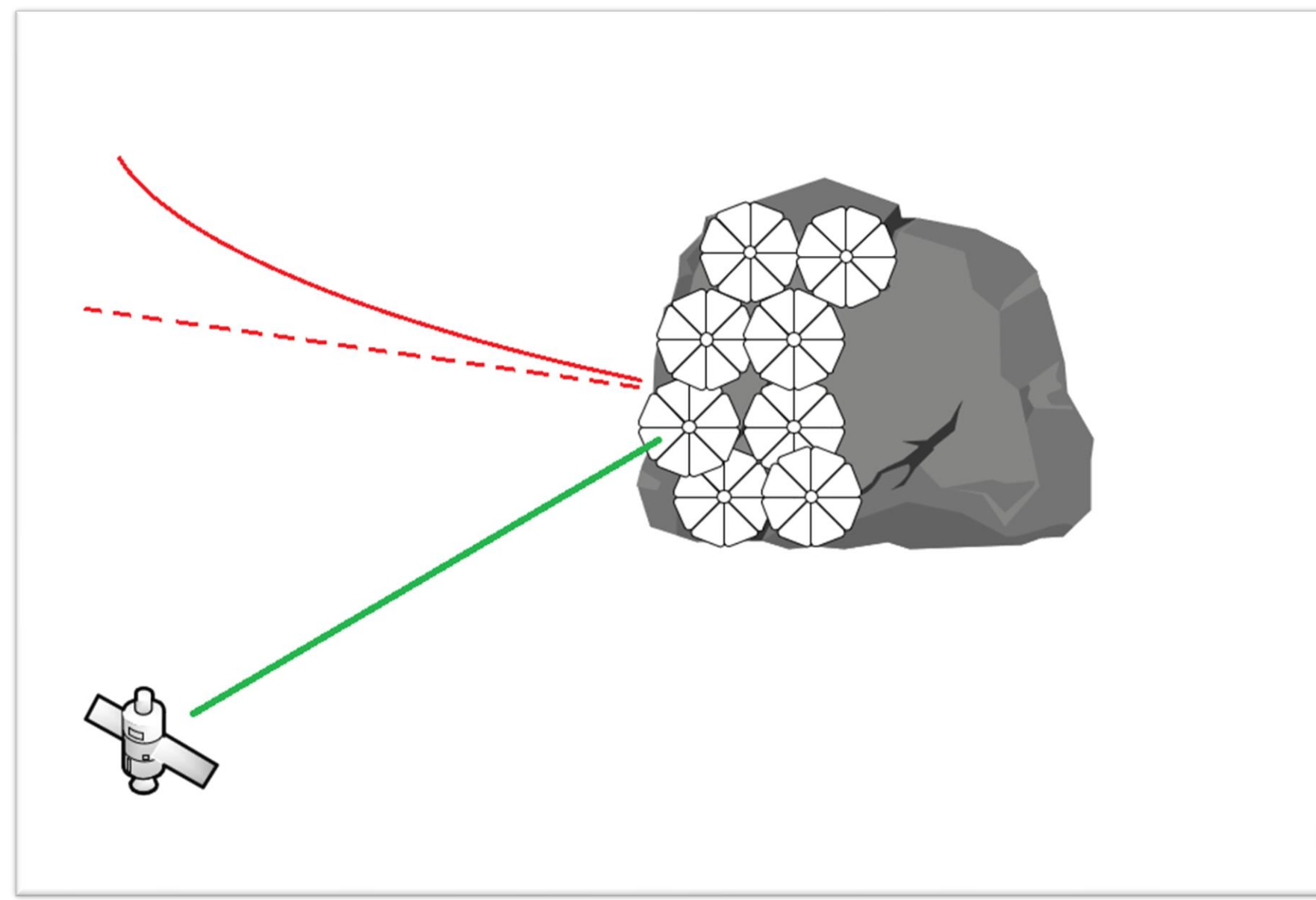

Combination of solar sail and laser techniques

Hard to attach a big solar sail on the asteroid's surface → divide them into multiple particles

These particles will be carried to the right place by little, hopping sensors

Sensors will determine their positions by their ranging messages' angle and time of flight

Because of this method, the surface of the solar sail can't be bigger, than the asteroid's surface, but laser energy can compensate the missing force

Sensor's structure

Parameters:

- Sensor's weight will be circa 5 kg, solar sail gives most of the weight, it is 4 kg, and located on the bottom of the sensor
- In open state the sail's surface is 150 square meter
- Upper 10 cm contains controlling and radio unit of the sensor, it can be fold down
- 3 AA batteries provide energy to the electromagnet and aiming engines and one bigger battery to the radio devices
- Sensor's shape is cube, so storing is easier in the carrier unit

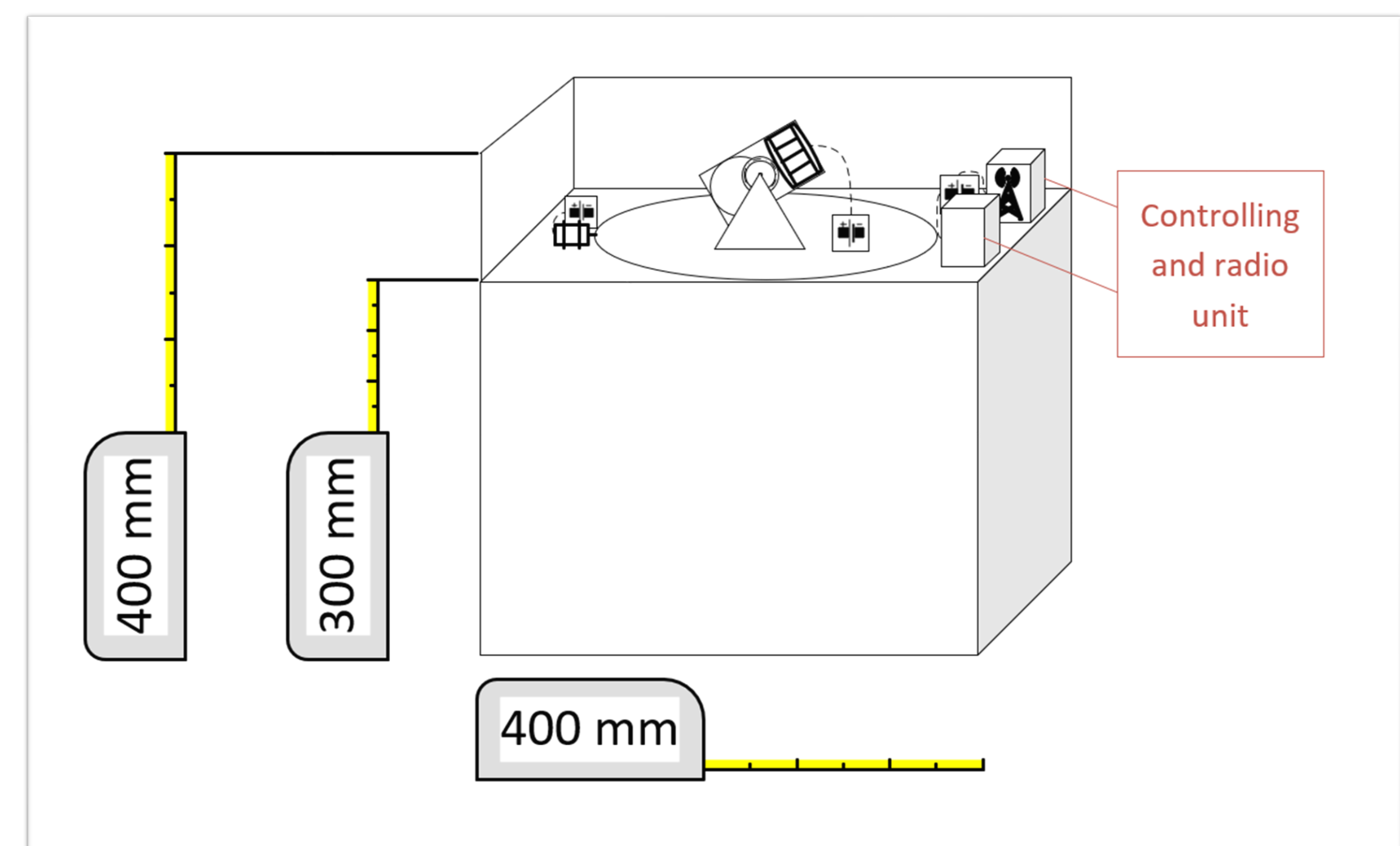

Moving on the asteroid

As the carrier unit goes close enough to the asteroid, weak gravitational force attracts it to its surface

Little sensors jumping out the carrier unit and move to their location one by one, they locating themselves with radio signals

Sensors hopping with an electromagnet which attracts an iron ball, and the ball's momentum moving the sensor

Electromagnet's pulling force can be modify, so sensor won't extend escape velocity

2 electric engines moving this cannon like structure, so the sensor's flying direction can be changed

These 2 engines work with 1-1 AA battery. Electromagnet needs another one to work, so the moving system needs 3 AA battery.

In the worst case, sensor could get around the asteroid with this amount of energy

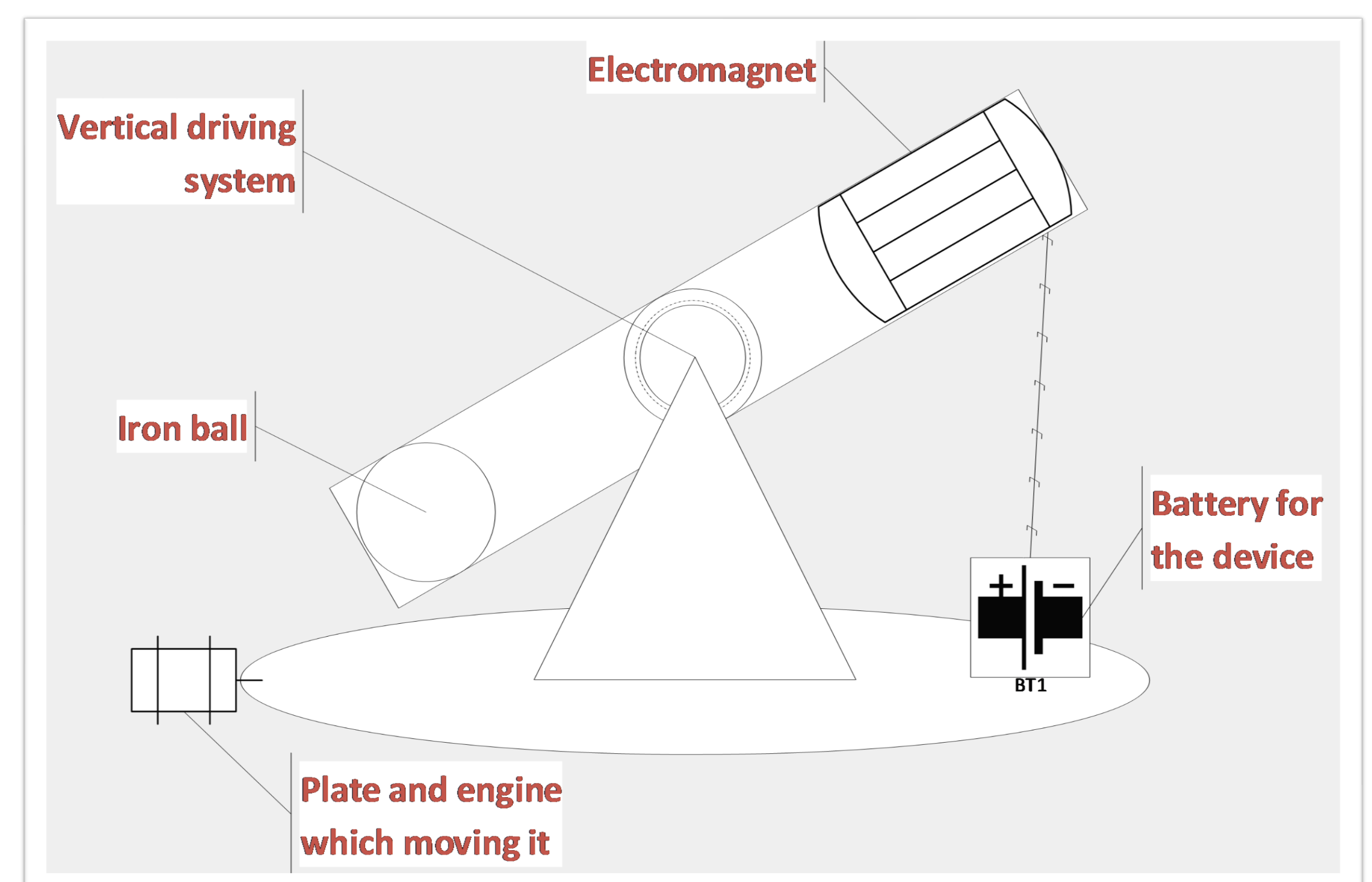

Calculations

Calculated with an existing asteroid's orbit, called Duende. Its average distance from the Sun is 0,9 AU

Calculations were made to 4 different asteroids, with different sizes

Sizes:

1. Dimorphos $5,1 \cdot 10^9$ kg, 200m in diameter
2. Bennu $7,3 \cdot 10^{10}$ kg, 500m in diameter
3. Icarus 10^{12} kg, 4km in diameter
4. Ida $4,2 \cdot 10^{16}$ kg 31 km in diameter

To make calculations easier, we imagined asteroides as spheres

To avoid collision, asteroid's orbit must change by 6800 km

As you see in the results, this deflection method is works, if the asteroid is small enough (not bigger than few hundred meters) and have enough time to change its orbit (10-15 years)

	5 year	10 year	15 year
Dimorphos	822,81 km	3291,25 km	7405,31 km
Bennu	313,69 km	1254,76 km	2823,21 km
Icarus	191,7 km	766,8 km	1725,29 km
Ida	2,23 km	8,91 km	20,05 km