

Prague-Dejvice railway station

V. Hansl & K. Bednařík

METROPROJEKT Praha a.s., Prague, Czech Republic

dh architekti

dh architekti, Prague, Czech Republic

ABSTRACT: The new Prague-Dejvice railway station is one of a series of structures connecting Prague, Václav Havel Airport, and Kladno. The construction is one of three sections connecting the airport to the Nádraží Veleslavín metro station. In this context, the construction will be operationally and technologically linked to the modernization of the Prague-Veleslavín (incl.) – Prague-Ruzyně (incl.) line and the new Prague-Ruzyně (excl.) – Prague-Václav Havel Airport (excl.) construction projects. This is an underground station designed in the relatively complex area of Prague's Hradčany district between Dejvická and Milady Horákové streets, which are at different elevation levels. The station is located in close proximity to the MO Blanka tunnel and has a direct connection to the Hradčanská Prague metro station. The station platform is variable in width from 7.9 m to 14.4 m and 221 m long with a boarding edge 550 mm above TK. The entire station is 12.5–45.0 m wide, and the entire cut-and-cover station structure is 459 m long. The depth of the platform below ground level is approximately 13 m. The station has a total of 6 levels, 2 of which are above ground. The above-ground floors house commercial units with a total area of approximately 7,000 m². The station roof is designed for the future addition of a 6-story administrative building. Documentation for the entire construction was prepared in the DUSL stage using the BIM method.

1. INTRODUCTION

The Prague-Dejvice railway station is part of the modernization of the Prague-Výstaviště (outside) – Prague-Dejvice (outside) railway line. The proposal involves the doubling and electrification of the existing single-track line and its partial tunneling in the range of approximately 1.409 – 3.646 km. In accordance with the assignment, the proposal is limited by the requirements for the direction and elevation of the railway line and the location of related structures. The section in question connects at its beginning to the already completed related construction project "Modernization of the Prague-Bubny (incl.) – Prague-Výstaviště (incl.) line." The line then runs above ground through Stromovka Park in the corridor of the existing track to the tunnel portal at the new km 2.054. This is where the planned tunnel complex with a total length of approx. 5.7 km begins, ending at the beginning of the Prague-Veleslavín railway station. The section Prague-Dejvice (excl.) – Prague-Veleslavín (excl.) is not part of this construction. The end of the construction is located at km 3.646, resp. 3.700, where the underground Prague-Dejvice railway station ends. This construction is followed by the project and construction of the "Modernization of the Prague-Dejvice (outside) – Prague-Veleslavín (outside) line.

Currently, this is section of railway line No. 120 (designation according to the printed timetable) Prague – Kladno – Rakovník. The existing line is single-track, non-electrified, with a line speed ranging from 40 to 70 km/h and a line load class of C2. The line is classified as a national railway line and, given the classification of Prague Airport as a major airport under Regulation (EU) No. 1315/2013 of the European Parliament and of the Council, the section in question is part of the TEN-T network.

The modernization of the line is proposed in its entirety as a double-track, electrified line with new Category 3 signaling equipment, remote traffic control, and increased line speeds to V100=80 km/h, V130=85 km/h, and V150=90 km/h.

The proposed solution for the railway station is essentially a new underground Prague-Dejvice railway station and tunnel structures. The surface route of the line, approximately in its current direction and elevation, is proposed in a short surface section running through the Královská obora (Stromovka) nature reserve.

2. URBANISM

The location of the railway station in the area is predetermined by the direction and height of existing structures – in particular the CC Blanka tunnel, the block of apartment buildings on Pod Kaštany Street, the existing Hradčanská metro station vestibule, and the proposed elevator connection to the Hradčanská metro station.



Figure 1: Orthophoto of the area under consideration.

This is an underground station with an island platform. The geometry of the track layout and the entire station is limited on the southern edge by the City Circuit Blanka tunnel complex and on the northern and eastern edges by existing buildings. The decisive factor is the adaptation of a direct elevator connection from the island platform of the railway station to the Hradčanská metro station. Both platform edges are curved, and their total length allows for the servicing of trains up to 220 m long. Based on the DOSS condition (Prague 7 Municipal District and Prague City Hall) submitted during the DUR discussion (compared to the previous phase of design preparation), the Prague-Dejvice railway station was redesigned. The change allowed for the placement of a multi-storey building above the station, which necessitated a reworking of the foundations and moving the building away from the CC Blanka tunnel. The railway station is located on its southern side approximately 2 m from the CC Blanka tunnel, allowing for the foundations to be dimensioned for increased loads. With regard to the urban connections in the area, three vestibules are proposed, supplemented by commercial spaces located on two floors (Lobby level and Ground level), so that the proposed construction is structurally, technically, and also from an administrative point of view, separable from the future completion of the multi-storey building.

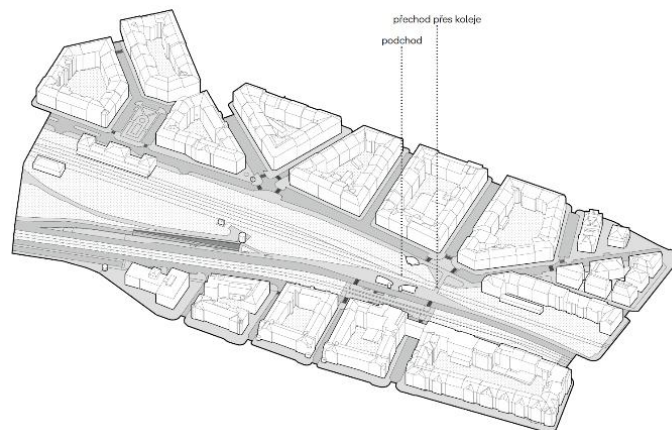

Figure 2: Axonometric projection of the current state of the territory.

3. LAYOUT SOLUTION

The basic spatial concept of the station is based on the requirements of the investor (Správa Železnic s.o. hereinafter referred to as SŽ) to ensure the possibility of full-fledged development above the station, to ensure a high-quality connection to the surrounding area, and to ensure a direct transfer link between the railway and the metro. The overall solution for the terrain levels is based on the limits of the track clearance height, the level of the vestibules, and the connecting commercial spaces. The development of the area further west will be established in the next phase in coordination with the Hradčanská urban study proposal.

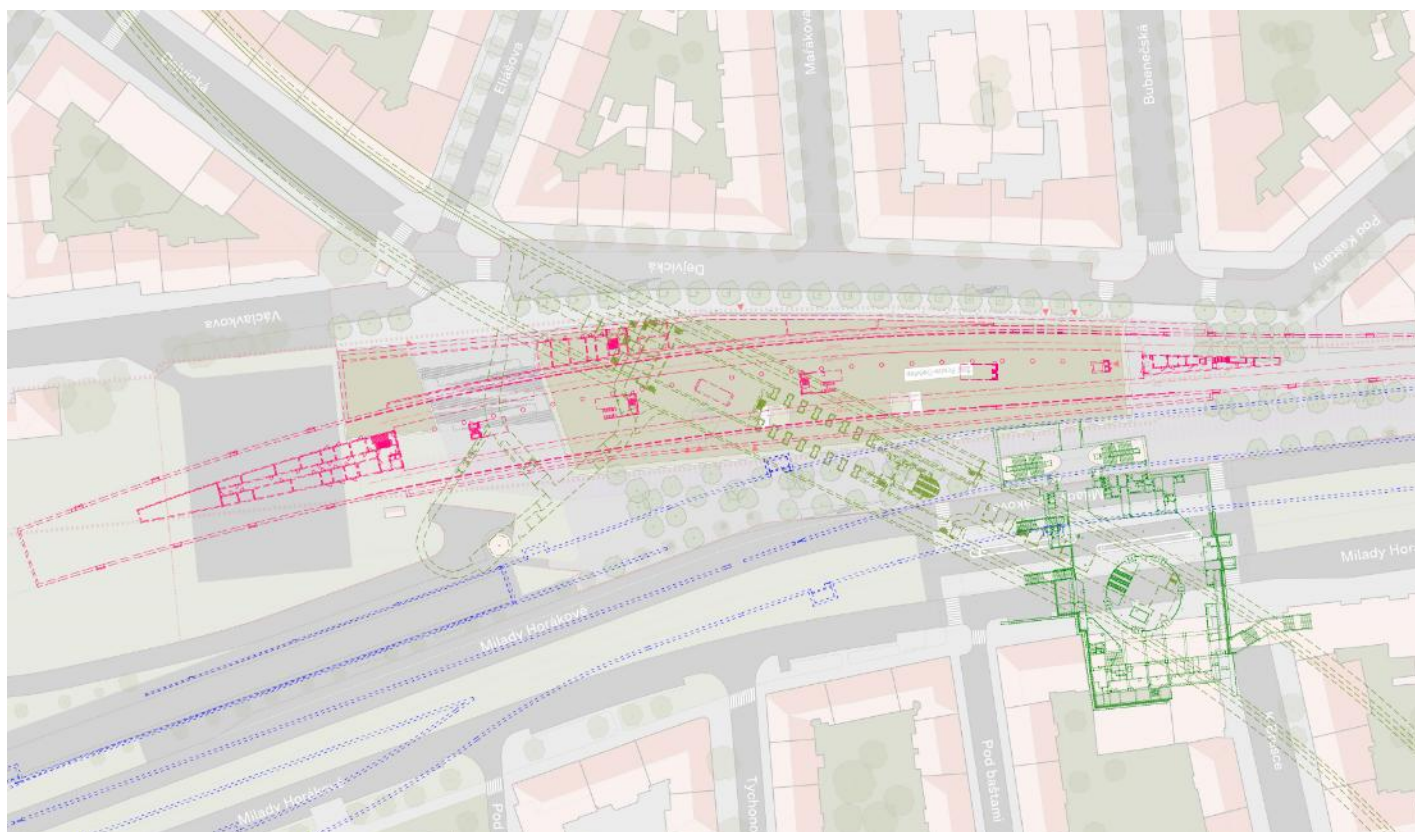

Figure 3: Situation with important structures highlighted – Prague-Dejvice railway station in red, CC Blanka tunnel in blue, and Metro A in green.

The station has a total of 6 levels (from the top):

- UT – terrain level – above ground
- UV – vestibule level – above ground
- UPV – level below the vestibule
- UN TECH – technology platform level
- UN – platform level
- UPN – level below the platform

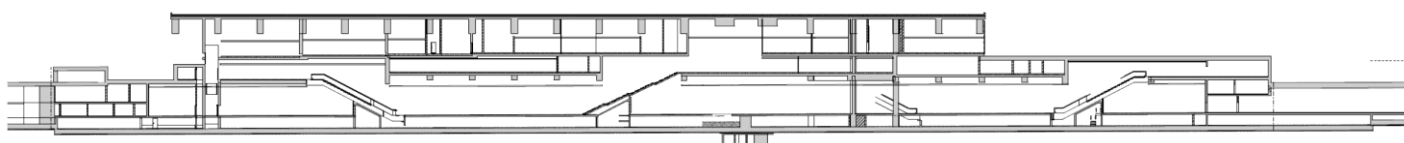

Figure 4: Longitudinal section of the station.

The station building will be completed in its operational state, including the elevated parterre on Milady Horákové Street. This will create a new city block between Bubenečská and Eliášova Streets. Adjacent to Bubenečská Street, a new station forecourt will be created, defined by its eastern façade. The significant elevation difference between Milady Horákové and Dejvická Streets will be addressed by a smooth slope of the terrain to create a barrier-free public space complemented by local greenery. The overall terrain leveling solution is based on the limits of the track clearance height, the level of the vestibules, and the adjacent commercial spaces.

The shape of the railway station had to be adapted to allow for the connection of both platforms, i.e., the railway station platform and the Hradčanská metro platform. The connection itself is designed using four elevators. Due to the confined space of the metro, the elevator on the railway station platform is outside the traditional orthogonal system, but this allows for a direct connection between the two platforms.

Above the ceiling slab of the railway station, a 6-story administrative building (locally up to 7 stories in the corners) is planned from an architectural, operational, and structural point of view, according to the investor's (SŽ) specifications. Within the above-ground part of the station (ÚV and ÚT), space has been allocated for the future administrative building for two elevator lobbies with three elevator shafts, four emergency stairwells with connecting vertical shafts for future technology wiring. The above-ground floors of the railway station, i.e. ÚV and ÚT, are used entirely for commercial units (total area approx. 7,000 m²).

The east vestibule has three escalators and a lift with three levels (ÚN, ÚV, ÚT), which connect to the existing Hradčanská metro vestibule and the public space on Bubenečská Street. The central vestibule, located at the intersection of Tychonova and Mařákova streets, is connected by escalators, staircases, and four elevators with four levels, including the metro platform, and provides access to Dejvická and Milady Horákové streets and the current bus stops.

The western vestibule is located at the intersection of Dejvická and Eliášova streets and offers access to Dejvická street via an elevator and three escalators.

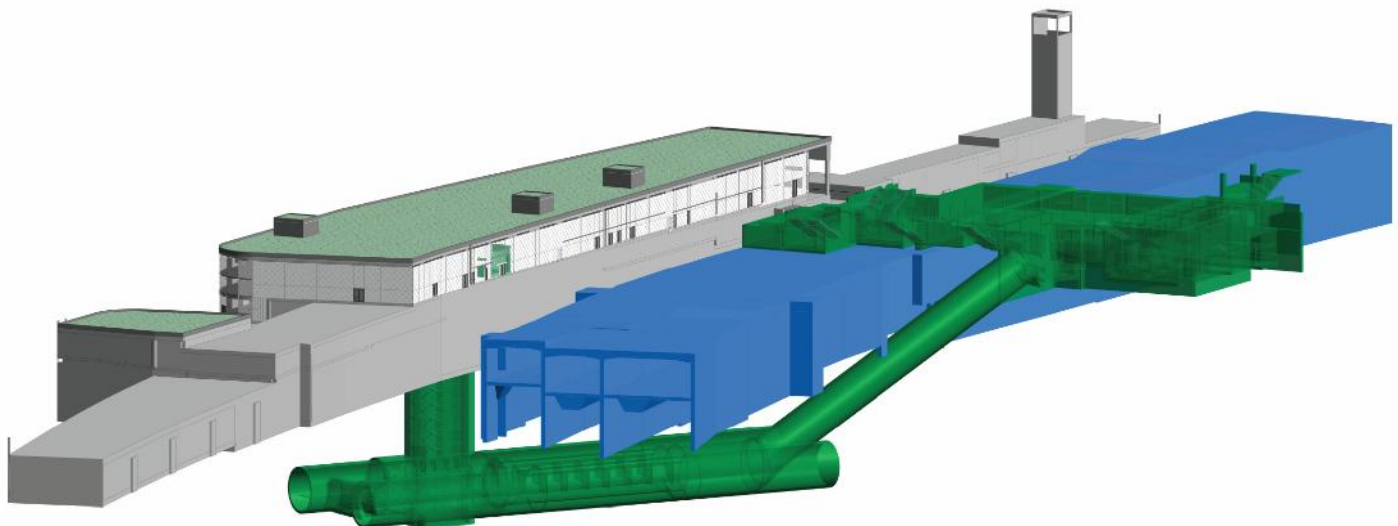

Figure 5: Axonometric projection of spatial connections – Prague-Dejvice railway station in full color, CC Blanka tunnel in blue, and Metro A in green.

One of the most complicated issues that had to be resolved during the design work was the connection to the project for Barrier-Free Access to the Hradčanská metro station (hereinafter referred to as BFA). As part of the BFA project, technology necessary for the functionality of all BBZ equipment (transformers, switchgear, etc.) was installed in the station premises, for which there was no space in the metro station itself. This technological block is completely separated from the station premises by doubling the reinforced concrete structures. In the ÚV, there is only an exit from the metro technology rooms to the ground on the facade of the railway station, which serves as a protected escape route (CHUC).

Given the very close connection between the two structures, it is essential that the construction of the BFA and the railway station proceed simultaneously. After excavating the railway station pit, the BFA

will be excavated from its bottom. The reinforced concrete structures of both buildings will be constructed simultaneously.

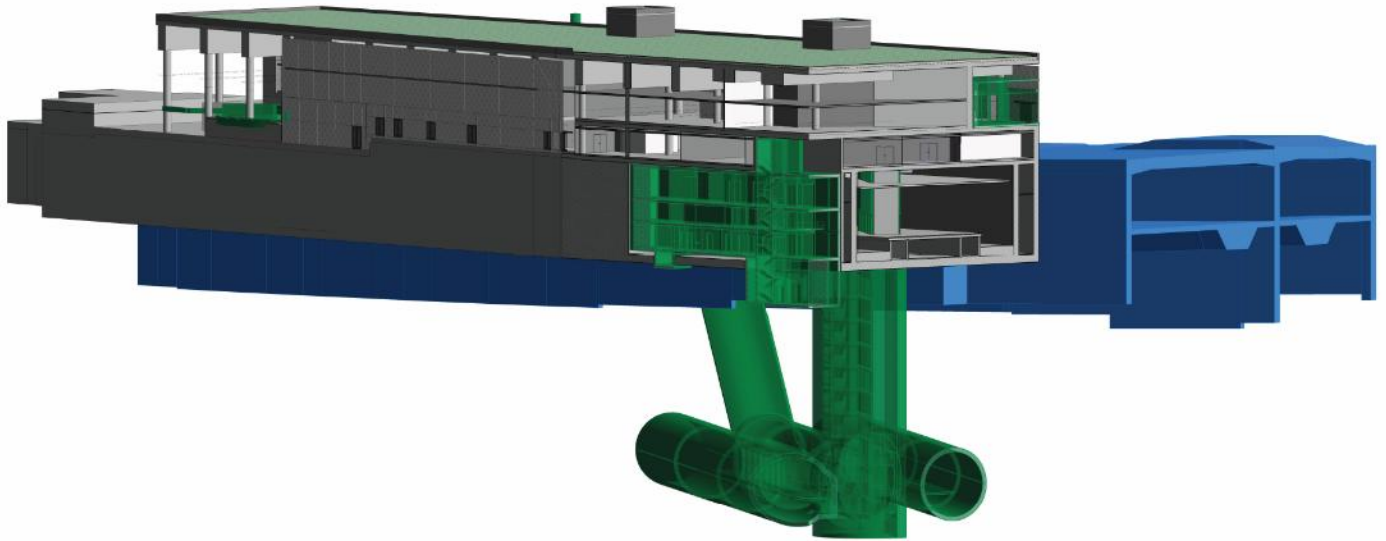

Figure 6: Axonometric section at the junction of the railway station and barrier-free access to the Metro and Hradčanská. Full color: Prague-Dejvice railway station, blue: CC Blanka tunnel, green: Metro A.

In addition to the technological block, another, even more significant element is the connection between the metro platforms and the railway station via four elevators.

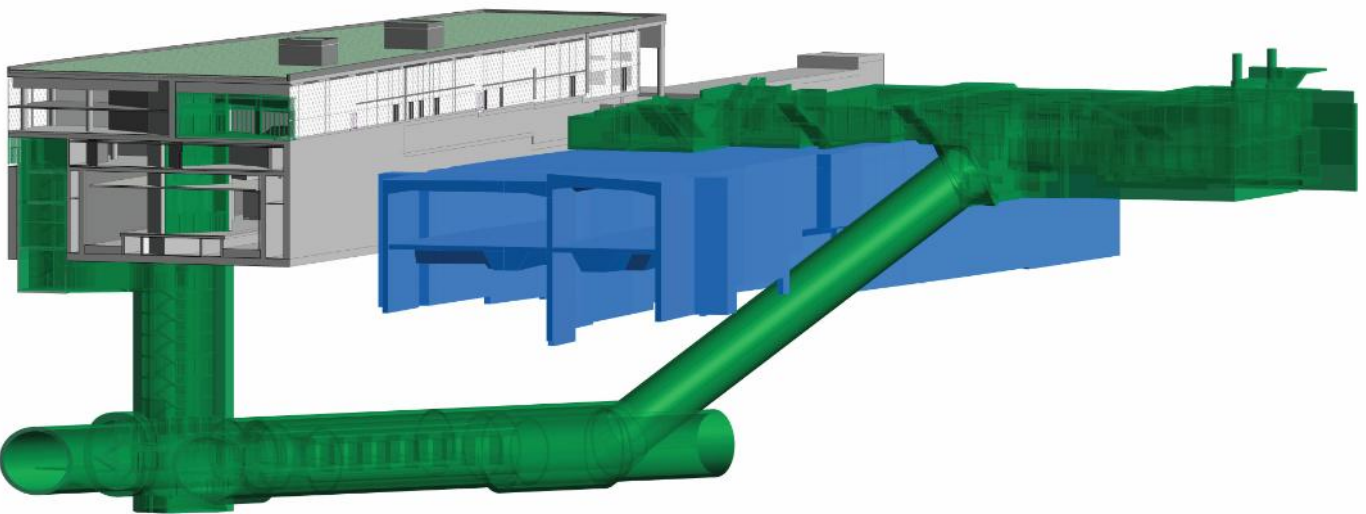

Figure 7: Axonometric section at the junction of the railway station and barrier-free access to the Metro and Hradčanská. Full color: Prague-Dejvice railway station, blue: CC Blanka tunnel, green: Metro A.

4. TECHNICAL SOLUTION

4.1 RAILWAY TRACK

A fixed track (FT) will be installed at the railway station. The FT will consist of prefabricated panels laid in a concrete base layer. The structure has been approved for SŽ railways. The FT covers 100% of the modernized section. Vibrations from railway operation must be dampened throughout the entire section, so a structure laid on longitudinal polyurethane strips will be used.

Under the FT, 1.1 m thick filling concrete is proposed in the station area to simplify the shape of the foundation slab as much as possible and minimize changes in height levels. Among other things, this will

also speed up construction. This concrete will be used to lay cables in cases where it is necessary to connect the cable duct in the track area and the technical area under the platform.

4.2 PLATFORM

The station platform varies in width from 7.9 m to 14.4 m, is 221 m long with a boarding edge 550 mm above ground level, the entire station is 12.5–45.0 m wide, and the entire cut-and-cover station structure is 459 m long. The platform level is located at a depth of approximately 13 m below ground level.

The height arrangement is derived from the height arrangement of the individual tracks. Both tracks are curved at the platform, without superelevation and with a gradient of 3 ‰.

The ground plan distance between the edge of the platform and the axis of the adjacent track in a straight line is 1680 mm.

Unlike a traditional railway station, the platform itself consists only of the floor structure. The underlying reinforced concrete structure is already an integral part of the Praha-Dejvice railway station.

Access to the platform is possible at a total of four locations: two sets of three escalators and two sets of two escalators and fixed staircases. Access is also possible via elevators located at both ends of the platform.

At the ends of the platform, there are steel stairs for descending from the platform to the tracks.

4.3 WATERPROOF

Reinforced concrete structures will be coated with modified asphalt strips, and bentonite mats will be used as a backup system to seal any defects in the main waterproofing layer. Some of the asphalt strips will be mechanically anchored to the supporting structure. The insulation is designed to protect against pressure from groundwater and the spread of stray currents and radon from the subsoil.

The expansion joints will be fitted with joint strips, which will be supplemented with injection tubes for possible injection of the expansion joints. The injection system will be led to the inner face of the reinforced concrete structure near the expansion joint.

4.4 SUPPORTING STRUCTURES

From a structural design perspective, the proposed reinforced concrete monolithic system of load-bearing structures is a combination of wall and column structures, with perimeter underground retaining walls, internal walls, particularly in the areas of elevator and stairwell cores and in areas separating functional units, and internal areas of the column system, which thus free up the internal layout. The ceiling structures are monolithic reinforced concrete, consisting of flat slabs of considerable thickness. The large spans of the ceiling structures are overcome by massive reinforced concrete beams supported on walls and columns.

In the longitudinal direction, the structure is divided into eight expansion units, with lengths ranging from 35 to 78 m. The expansion joints are located with regard to the different masses of the supported structures of the upper floors and, in particular, with regard to the longitudinal layout with the resulting location of escalators, elevators, and staircases.

The building is founded on a flat reinforced concrete monolithic foundation slab of uniform thickness with only two changes in height levels and a slope given by the level of the railway track. According to information from the engineering-geological survey, the foundation slab will be set in layers of fluvial gravel, which will be improved by jet grouting pillars to the required bearing capacity for contact stress in the foundation joint. The improved subsoil will also create a hidden strut in the horizontal direction, preventing horizontal displacement of the perimeter wall of the existing city ring road tunnel structure after excavation of the construction pit.

Above the UT level, a massive superstructure "platform" is designed to form the base for a future six-story extension of the administrative building. The "platform" for the superstructure, which forms the ceiling structure above the UT, is designed as a 0.5 m thick slab supported on massive beams with a cross-section of 1400 (w) x 3500 (h), spaced at 8.9 m intervals.

4.5 CONNECTION TO CUTTING TUNNELS

The tunnel is designed as a double-track, monolithic reinforced concrete single-span frame with a track center distance of 4000 mm. The dimensions of the tunnel are selected to meet the requirements of the Combined Tunnel Clearance Profile according to ČSN 73 7508 and the requirements for drainage of the railway substructure. The distance between the track axis and the tunnel wall is 3425 mm, which ensures an escape route on both sides of the tunnel with a minimum width of 1200 mm and a minimum height of 2250 mm. The tunnel is equipped with rescue niches on both sides with a depth of 750 mm at an axial distance of 24.0 m. These niches continue into the Světlá railway station. The clear height of the tunnel above the track is 7500 mm and the safety space around the entire perimeter is 300 mm. The grade of the cut-and-cover tunnel in this section is approximately 11-14 m below ground level.

4.6 HEAT AND SMOKE EXTRACTION FROM THE PLATFORM

For heat and smoke extraction, an Main Ventilation machine room with two axial fans ($2 \times 60 \text{ m}^3/\text{s} = 120 \text{ m}^3/\text{s} = 432,000 \text{ m}^3/\text{h}$) is designed for the Dejvice railway station. The machine room is identical to the ventilation system for the transport system. HVAC ducts for smoke extraction are designed on the sides of the station, the layout of which is determined by the surrounding buildings and the above-ground part of the station. The HVAC ducts are designed along the entire length of the public part of the platform. The smoke extraction itself will take place through openings located under the ceiling and connected to the platform area by means of a shadow groove in the suspended ceiling above the platform.

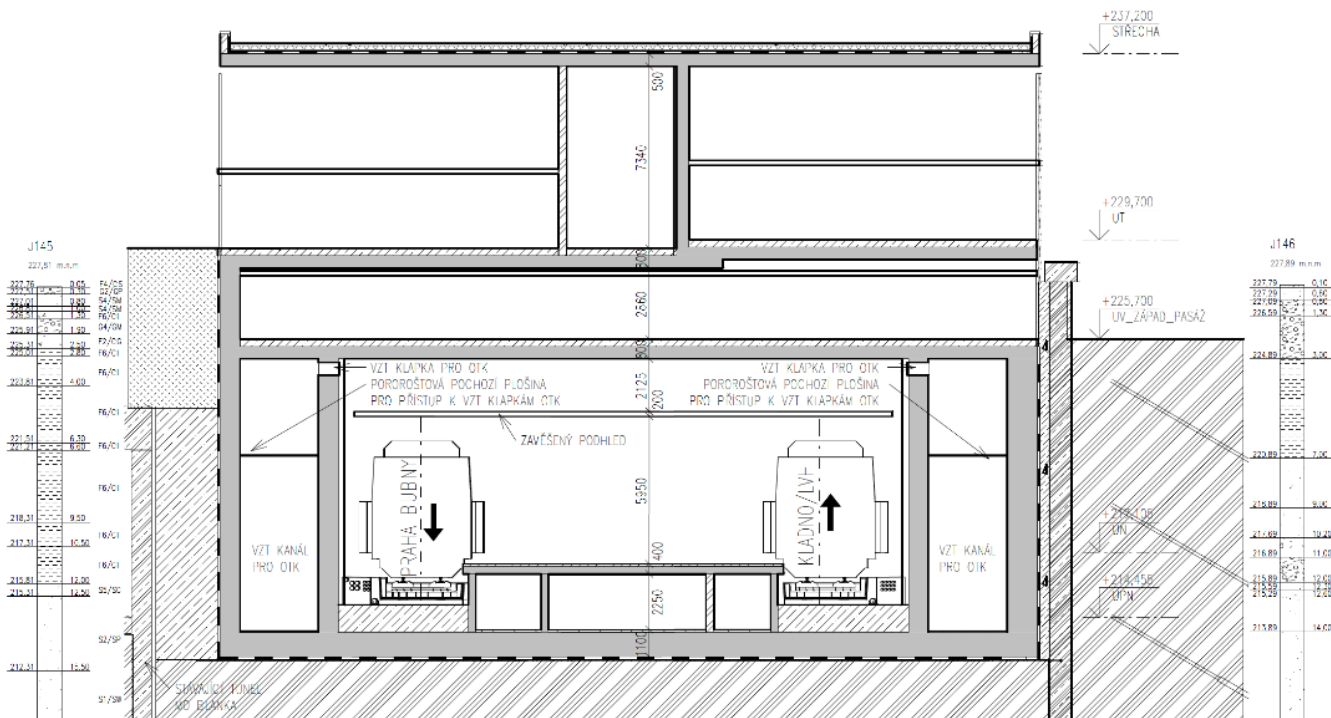

Figure 8: Cross-section of the station with VTZ channels marked.

The amount of extracted air ensures the removal of heat and smoke in the event of an accident, fire, etc. In the event of a fire in a carriage in a railway tunnel, it is necessary for the train to either reach a station or exit the tunnel. Evacuation of passengers is much safer at the station. If the train with a burning carriage remains in the tunnel, it will be necessary not to start ventilation for 6-8 minutes in the first phase. Combustion products due to higher temperatures under the tunnel ceiling, if the longitudinal flow velocity in the tunnel is up to approx. 1.5 to 2 m/s. During this time, it is possible to safely evacuate people to the surface via the fire escape staircase. After the combustion products have cooled down partially, the smoke will begin to settle, and once the evacuation of people from the tunnel with the burning carriage has been completed, it will be possible to start the exhaust fans and ensure that the combustion products are extracted to the surface. Fire fans, dampers, and silencers are designed for a temperature resistance of 250 °C for 90 minutes.

5. CONCLUSION

The construction of the Prague-Dejvice railway station will be part of a relatively large development planned for this area. The space is roughly defined by the location of the railway station and Svatovítská Street. The Hradčanská Land Use Study is currently being prepared (by M4 architekti, commissioned by the Prague City Council).

The construction of the railway station and the barrier-free access to the Hradčanská metro station will give the area a very strong connection to underground transport.

Ing. Vítězslav Hansl

METROPROJEKT Praha a.s., Argentinská 1621/36, 170 00 Praha 7

Vitezslav.hansl@metroprojekt.cz

Ing. Kamil Bednařík

METROPROJEKT Praha a.s., Argentinská 1621/36, 170 00 Praha 7

Kamil.bednarik@metroprojekt.cz

dh architekti

dh architekti s.r.o., dejvická 9/306, 160 00 Praha 6 - Dejvice

office@dharchitekti.cz