

Water Management Solution

Powered by **IoTivity**



Who We Are

Incorporated in 2017, we are a technology driven, DATA acquisition & Connectivity provider company. IoTivity strives on SIM – **SMART, Innovation & Management**, with its focus on to bring out the best of the man and machine harmony.

We primarily work as an IoT based complete solution provider, that aims in creating socio impact. We recognize the ever-changing techno-commercial diorama and constantly keep updating ourselves to cater our client's need and keep their business running smoothly.

A humble start with a mix of passionate business professionals and technology experts, which gives us the ability to have a better understanding of not only client's technical needs, but provide them a value for money solution each time.



An ISO 9001:2015 & ISO / IEC 27001:2013 Company



2017 Founded



100+ Satisfied Customers

Our Vision & Mission

Our Vision

Go Green – Drive IoT enabled “Green India”.

Our Mission

Align with Global initiatives in contributing to making India a Smart, Clean, Green, Rich in natural resources nation using IoT.”

Already aligned with Govt initiatives like Nirmal Bangla, SBM, Water Policy, AMRUT, JNNURM etc.



Snapshot of What We Do



Connectivity Solution

We are the second company in the country to introduce multi-operator embedded SIM into the country. Under the mandate of Govt. of India these are used in m2m communication and AIS140 standard GPS-VTS applications as part of the GOI's intelligent transport project.



Smart Environment Management

For advanced users we provide remote control solutions based on our in-house developed application platform for river water flow & level monitoring, temperature and humidity monitoring, environment and weather stations (Disaster management), pollution control.



Smart Water Management

We have expertise in sensor based automation of various use cases in SMART Water Distribution and Quality Management using IOT technologies. We provide water pump automation and level management solutions in the domestic, commercial and industrial sectors along with host of other sensor based solution.



**SMART WATER
MANAGEMENT
PRODUCTS**

Level Transmitter



Controller



Transmitter



Repeater

Water Level Sensor (Industrial Grade) :

- Water level sensors to measure water level with 1% resolution and flow/ overflow status and can transmit the data wirelessly to controller cum receiver unit. The water level sensor is able to measure water level in %age of full depth of tank. It is weather proof with clamping/ fixing arrangement. It will automatically calibrate the depth of the tank in percentage. .
- Water level sensor to measure water level with < 99% accuracy.
- Input Flow / over flow status
- Provision of connection with Digital Transmitter.
- Teflon coated sensor with continuous water level indication
- Capacitive sensor for continuous data
- Water Level Sensor: PTFE material coated flexible capacitive sensor.
- 03 sensor Node , Low level, High Level and Over flow
- Flow Sensor with RF wireless interface.

LORA Based Water Meter

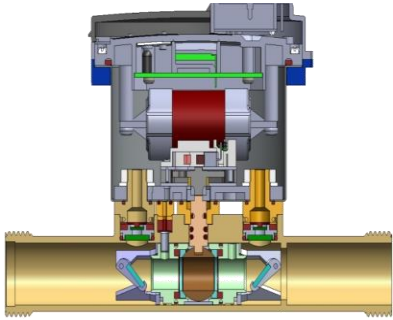

The device is composed of Ultrasonic water meter, Wireless Concentrator and Software Data Center. The transmission method is wireless Lora technology. There is no need to install wires, so it is easy for calibration and maintenance which makes this proposal convenient for various complicated environment applications

Features

- ❑ Low starting flow, high steady flow
 - The starting flow for DN15 is less than 1.5L/h, even small drops of water can be measured.
 - To reduce the loss of the water supply company by calculating the flow hasn't been measured before.
- ❑ Long Life Span
 - No moving parts, Wear-free technology.
 - Long life span, low usage cost
- ❑ Bi-Directional Flow Measurement
- ❑ Measure both forward and reverse flow

LORA Based Water Meter

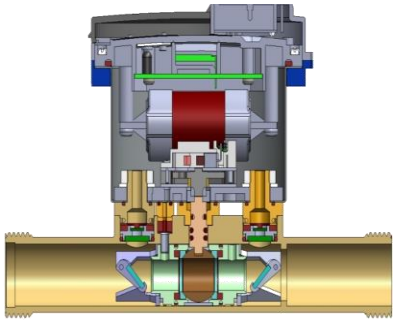

Concentrator Overview

- The wireless concentrator collect data from the water meter Then upload the data to the data center through GPRS.
- The concentrator has two antennas
- One is Lora antenna to collect and communicate with the water meter
- The other is GPRS antenna to communicate with the data center

Technical Specifications

- Lora Wireless Technology
 - Long range, the transmission range can be up to 3Km on the open ground
 - Reliable anti-interference ability
 - 1 concentrator is enough for a height of 33 floor building,
- Large load capacity, support up to 1000 slave meters
- Three types of power supply method
 - AC powered
 - Solar Panel powered
 - Battery Powered

Smart meters collect water consumption data with a timestamp and transfer that information to the utility. This can either be a one-way communication to the utility (AMR — automated meter reading) or a two-way communication between the utility and the individual smart meter (AMI — advanced metering infrastructure).

Advantages

- Reduced Meter Reading Cost
- Reduction in security & safety issues
- Increased Customer Service
- Leak Detection
- Reduction of unaccounted water
- Increased billing & cash flow
- Improved Outage information and response



Model - K SMART



Features:

- AMR Ready / AMR (Wireless)
- Multi Jet, Magnetic Transmission
- Hermetically Sealed Register with protection category of IP 68
- Register with 7 rollers & 1 pointer
- As per IS 779:1994 & ISO 4064

Standards

- Size Range 15 MM to 50 MM
- FCRI Passed Performance Test for 15mm
- FCRI Passed Life Cycle Test for 15mm under Model Approval Program

Model - ULTRA-G Cyble



Features:

- AMI Ready / AMI (Wireless) IoT Connectivity
- Transmits data via Sigfox or LoraWan
- Low Power Radio Communication
- Uni or Bi-Directional Radio Transmission
- High Capacity data storage
- On line Alarms
- 10 Years Battery Life
- Suitable for flooded pits
- Data Encryption
- External Antena enhancing range
- Installed Directly on water meters.

Contact Us



WE ARE
JUST A CALL AWAY

REGISTERED OFFICE

IoTivity Communications Pvt.Ltd

HMP House, 4 Fairlie Place,
Mezzanine floor, Room No 3,
Kolkata, West Bengal,
India, Pin-700001

CORPORATE OFFICE

IoTivity Communications Pvt.Ltd
EE-8, Natya Bhavan (3rd Floor),
Near WIPRO more, Sector II - Salt
Lake,
Kolkata -700091, West Bengal, India.



OR



+91-8910308853
+91 8512824388



info@iotivity.in
care@iotivity.in

Thank You