

Water in balance

NeoFlow Pressure Regulating Valve



Water in balance

GF Piping Systems NeoFlow allows intelligent balance, precise and optimized pressure management to create complete harmony within your water distribution network.

Without pressure management equipment, water distribution systems can be confronted with unnecessary mechanical stress which can only result in accelerated ageing and loss of performance. The relative reliability of existing pressure control valve prevents water utilities from optimizing their operation. The heavy maintenance routines imposed by the rather "antique" mechanical design increases cost of daily operation and the restricted flow range often creates non-optimal pressure conditions, eventually resulting in dramatic failure in the drinking water supply.

Conserve what is most precious. Create complete harmony in your water network.



NeoFlow Pressure Regulating Valve

**Extremely accurate
and stable pressure
regulation under any
flow conditions.**

Water loss is preventable. Protect your water distribution network from excess pressure and reduce leakage rates and pipe bursts. NeoFlow is a state-of-the-art technology for a pressure management valve that can prevent your pipes over-pressurizing while delivering accurate, stable flow, and increased flow capacity to utilities. Thanks to compact and lightweight polymer body design, NeoFlow is up to nine times lighter and can decrease installation time by up to 40% compared to standard metal PRV.

Fully customizable, this intelligent valve is integrated to optimize pressure regulation in the most cost-efficient way. Available with an additional pre-fabricated integrated plug and play solution, the NeoFlow ensures long-lasting, hassle-free operation even in the tightest manholes.

It's time now to protect, manage and conserve what is most precious. It's time for water in balance.

Everything in balance



NeoFlow



Protect

Water in balance

Protect your water distribution network from excess pressure and reduce leakages and pipe bursts with optimized pressure management.

Networks in balance

With intelligent balance, precision and control of water, the protection of network stability is accurately managed for water distribution utilities worldwide.



Manage



Conserve

Costs in balance

Free engineers from time-consuming, labor intensive installations versus heavy ductile iron alternatives with a lightweight polymer solution, minimal maintenance and longer operational lifetimes.

Resources in balance

Pressure management reduces excess consumption, existing leakage and unnecessary mechanical stress. Water is conserved and network durability is improved.

Networks without compromise, turn challenges into opportunities

What is non-revenue water?

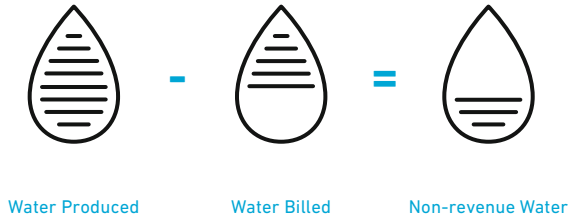

Due to the aging water distribution infrastructure, non-revenue water (NRW) is a major issue for water utility companies across the globe.

Highlighting impact of non-revenue water

Current data indicates that the majority of utilities have 20-50% water loss. It is estimated that water utilities around the globe lose up to USD 39 billion¹ per year due to non-revenue water.

Besides the direct cost of water loss, water utility companies also face indirect material costs such as energy consumption costs from pumping and financial penalties due to missed non-revenue water targets from the regulatory bodies as well as pressure from the public. Reducing non-revenue water is challenging for water utilities due to high cost construction of new asset network, complex underground asset systems, difficult repair tasks, traffic disruption and increasingly cumbersome leak detection technologies.

Challenges



Non-revenue water

126 billion cubic meters of non-revenue water is lost globally at a cost of USD 39 billion¹ to utility companies.



Pipe burst disruption

Water distribution utilities worldwide suffer serious water pipe failures every year, losing water and millions of dollars due to expensive emergency repair tasks and asset renewals as well as interrupting supply to end-customers and substantially harming the reputation of the water utility.



Low energy efficiency

Pumping and water treatment energy costs represent the highest operating expense after manpower. Beyond its financial impact, this contributes negatively to the reduction of CO₂ emission targets.



Water scarcity

Maintaining water security and overcoming drought events is increasingly difficult due to the rising impact of climate change. Extreme events are becoming more frequent in every part of the globe, even in mild climate regions.

¹ Quantifying the global non-revenue water problem. Roland Liemberger/Alan Wyatt

² Reference document Good Practices on Leakage Management WFD CIS WG PoM

³ The Carbon Footprint of Water. Bevan Griffiths-Sattenspiel/Wendy Wilson

⁴ Fossil CO₂ and GHG emissions of all world countries, European Union, 2019

⁵ Anthropogenic influence on the drivers of the Western Cape drought 2015–2017

Opportunities



Conserve water resources

Ensure sustainable conservation of precious water resources by implementing pressure management. Reducing system pressure by 20% reduces flow rates of existing non-revenue water leaks by 20%² and helps optimize leak detection, construction of new asset networks and disruptive repair tasks.



Decrease emergency repair cost and enhance renewal plans

Reducing pressure in networks by 25% means unnecessary mechanical stress is avoided and burst frequencies are reduced by up to 75%². Reduction in pipe bursts can also help defer some critical pipe renewals and increase overall end-customer satisfaction.



Increase sustainability impact

By reducing water loss, less water needs to be treated and pumped through the system. Consequently the energy needs can be decreased in an efficient way. In the US a 5% reduction of water leakage can save up to 225'000³ metric tons of CO₂ annually, the equivalent to the annual CO₂ emissions of 14'000 US citizens⁴.



Strengthen climate resilience

Due to climate change, the risk of a dramatic drought like the Day Zero scenario in Cape Town is now 3.3 times higher⁵. A sound non-revenue water strategy with intelligent use of pressure management can help mitigate this risk, creating a buffer by conserving water.

USD39bn

is the estimated yearly global cost of non-revenue water to utility companies¹

75%

reduction in pipe bursts by decreasing excess pressure by 25%²

5%

reduction of water leakage can save up to 225'000 metric tons of CO₂ annually³

3.3x

higher risk of a dramatic drought due to climate change⁵

Beautifully designed

Smooth operator

Bar

2.25

Utility operation

With NeoFlow, water utilities can easily implement pressure control technology to benefit from a protected water network.

Versatile flow control

The axial flow design enables the valve to be fully operating at a 1% to 100% opening, delivering extreme precision and stability.

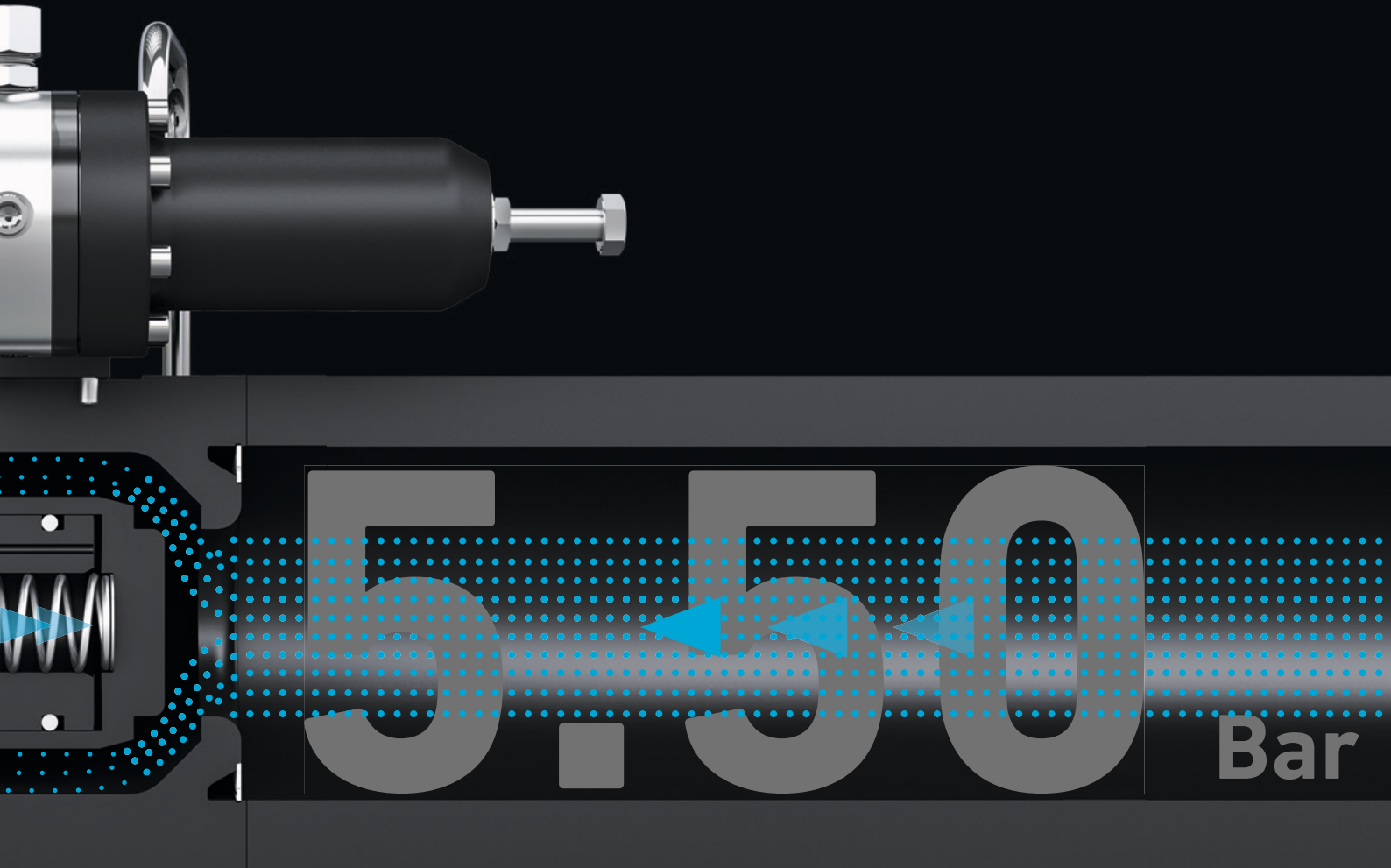

Application modifiable

Fully customizable to fit the most challenging installation conditions in the most cost-efficient way.

Less maintenance

The valve can be fully serviced in less than one hour due to its mechanical simplicity and low weight.

Compact, intelligent, and low maintenance

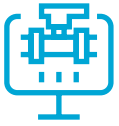

Smart valve

Integrated pilot valve to optimize pressure regulation and optional integrated equipment to monitor flow, and water quality.



No actuator stem or diaphragm

Significantly reduced complexity. Low maintenance requirements due to very simple design with few components and no elastomer diaphragm.



Axial flow

More accurate and very stable flow (down to zero), even at a small operating differential. Higher flow precision, also enabling pressure management in low pressure systems.

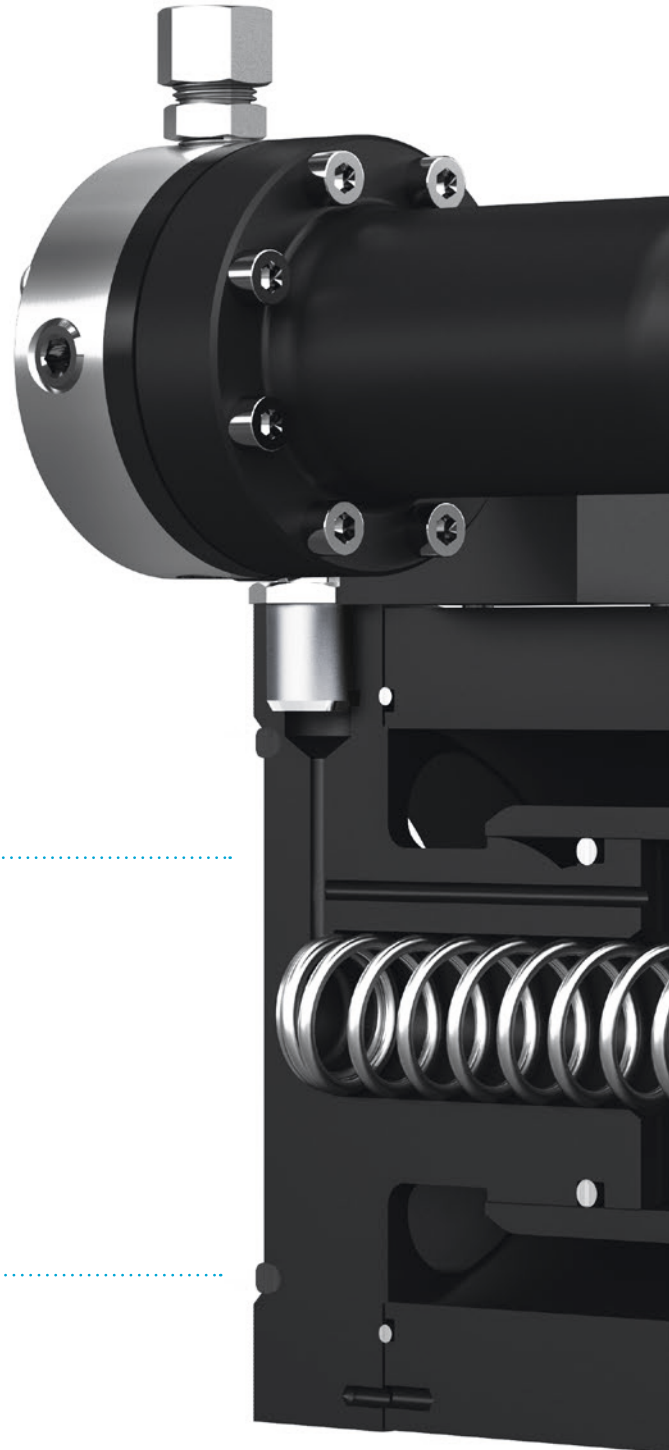

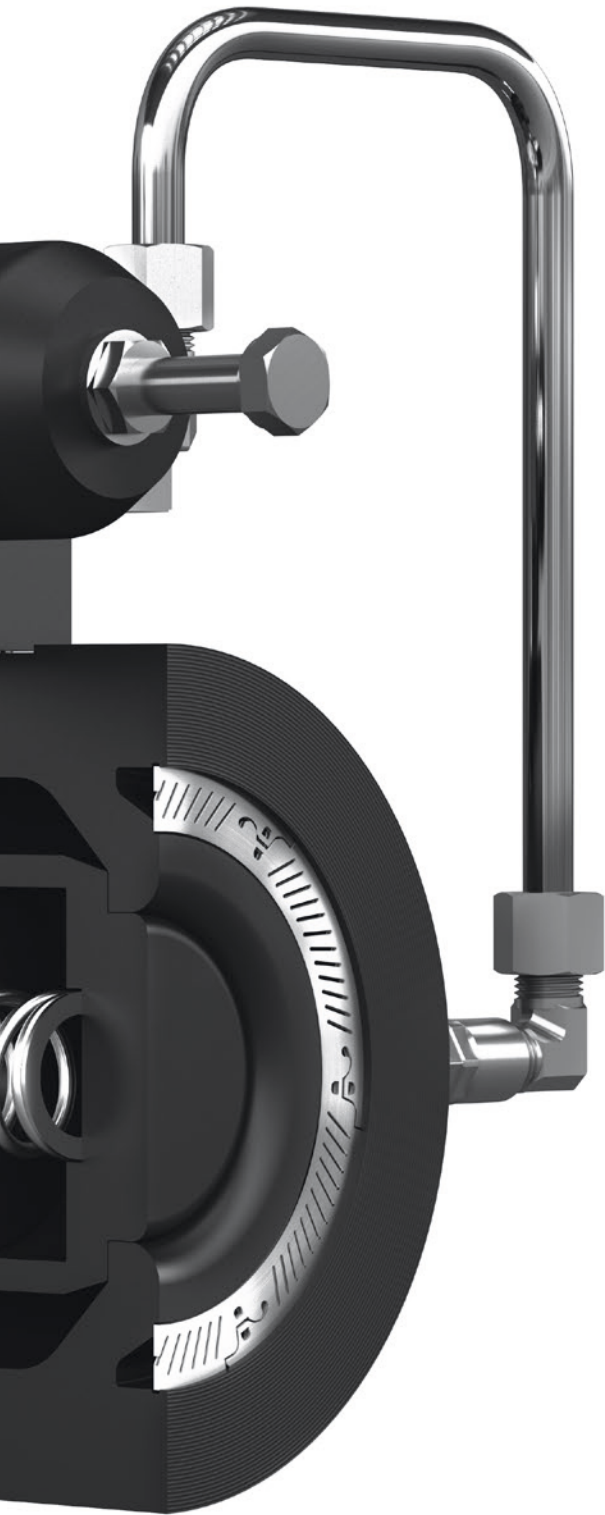

9x

lighter than a standard metal PRV

5x

more compact than a standard metal PRV

40%

less time to install than a standard metal PRV

Benefits

Lightweight polymer, heavyweight benefits

The output is what matters

Due to the innovative geometry, the valve regulates outlet pressure to be stable and reliable – regardless of whether the flow is very small, and the valve is only slightly open, or the flow is approaching the maximum value and the valve opens almost completely.

Advantages of compact design

The compact design offers advantages in logistics, handling and installation of the valve. Furthermore, when designing a new system, this advantage can be used to save valuable space. Existing systems can be upgraded by installing additional measuring instruments, without having to make changes to the piping system.

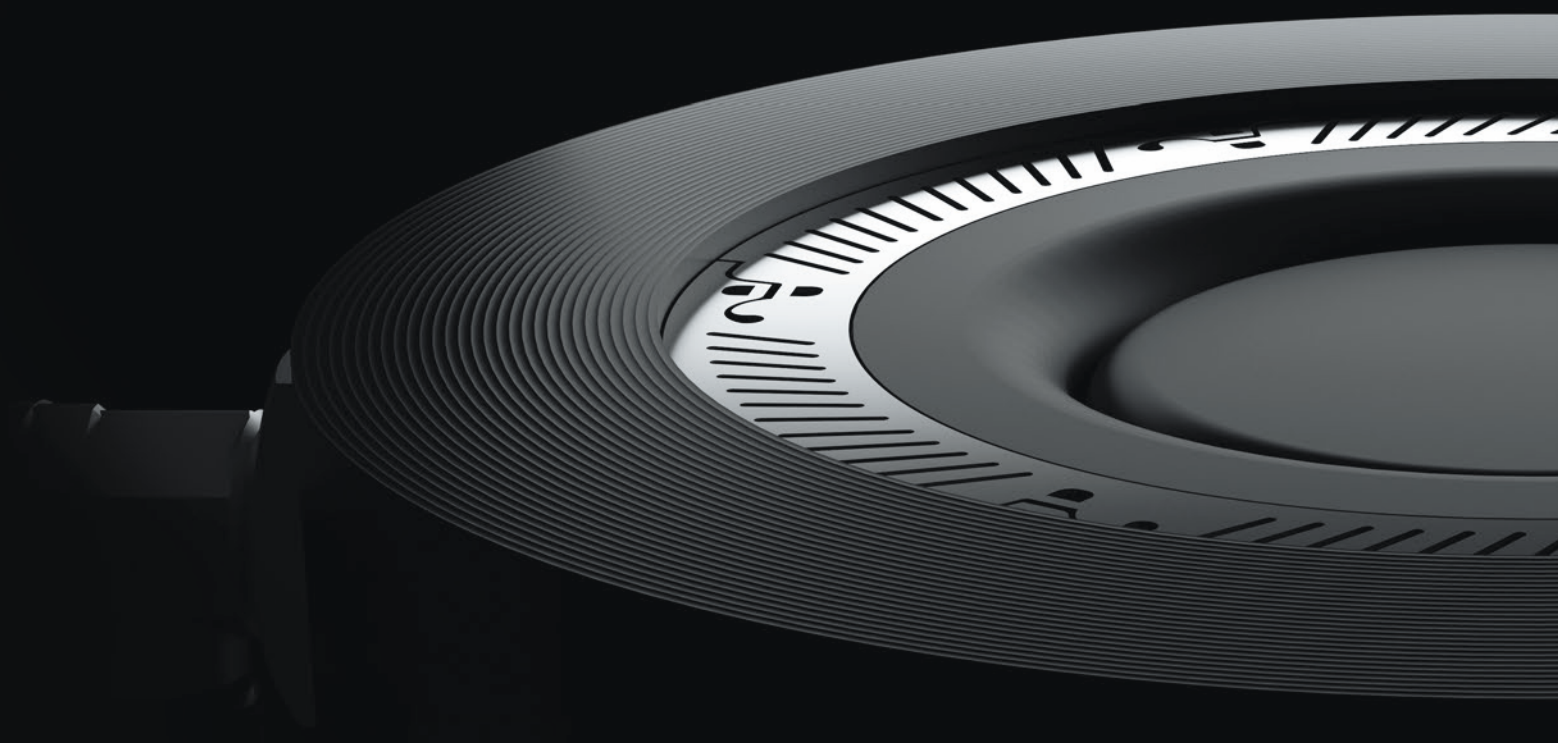

Space for measurement

Different monitoring and control devices can be connected via the interfaces on the valve body. Sensors provide the necessary information and actuators change the control parameters according to customer requirements. The axial flow geometry of the valve generates little turbulence, which is why a flow meter can be installed directly adjacent to the pressure regulating valve.

Versatile by design

Thanks to the wafer style design, the pressure control valve is perfectly suited to adapt to any situation and can be configured according to customer specifications. Thus, different connection technologies and unit systems can be implemented with one solution. The low weight of the valve makes handling easier and offers new possibilities for designing systems.

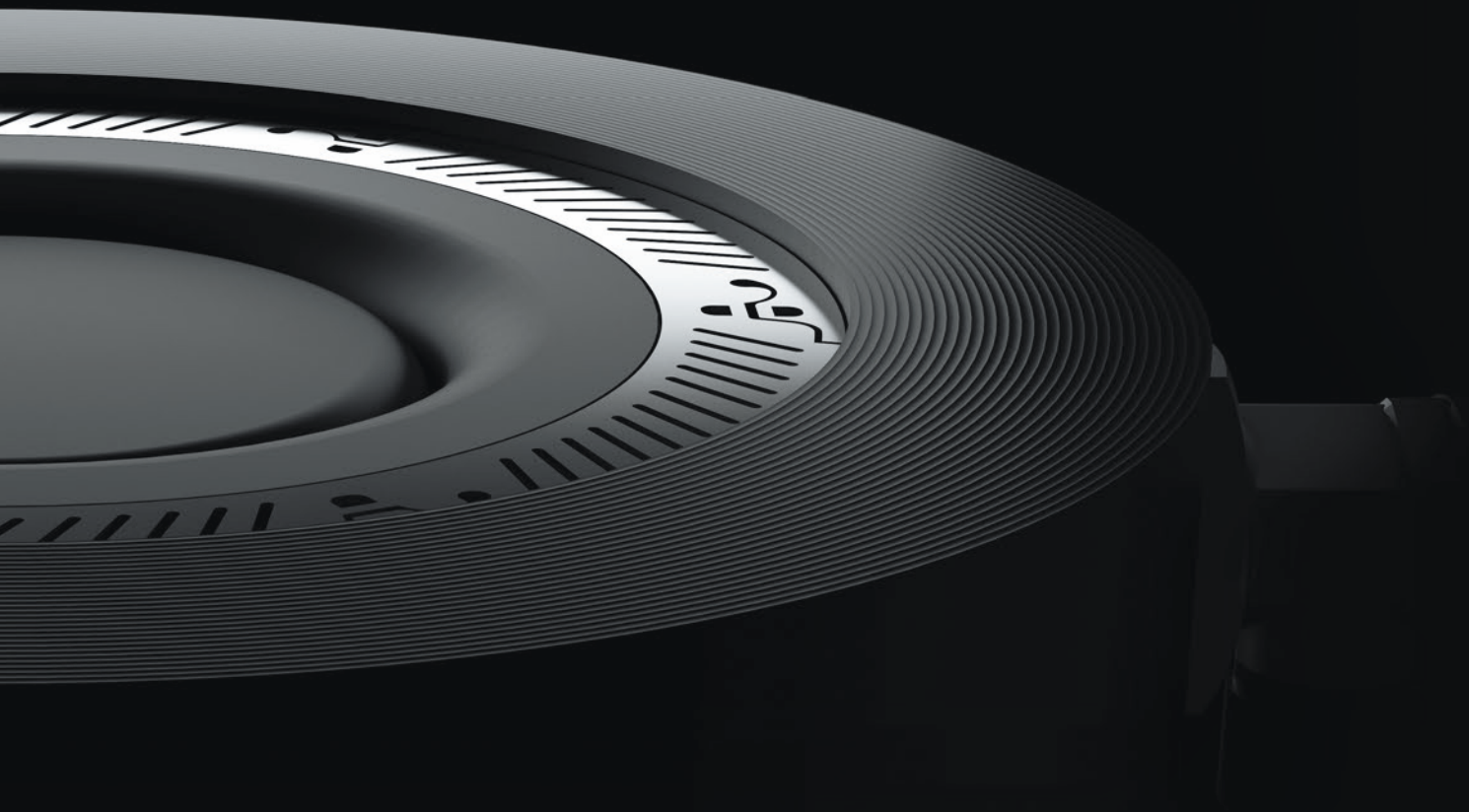

Applying pressure

Pressure management technologies are widely considered as one of the most effective methods to reduce non-revenue water. They reduce the flow rates of existing leaks and limit unnecessary mechanical stress on the infrastructure, which eventually results in lower burst rates and prolonged asset life.

Pressure management

Pressure management is used to deliver the exact necessary pressure at every point of a water distribution system. This allows to reduce leakage as well as relieving mechanical stress and prevent further pipe bursts.

Pressure reducing valves

Pressure reducing valves can be used in water transportation or distribution, generally to protect the down-stream network against excessive pressure.

Tank level control

Valves can be used in water transportation, generally to manage the level of storage tanks with or without the help of a floating element inside the tank. This valve opens and closes at a predefined level. They should generally be associated with a pressure sustaining function.

Pressure sustaining valves

Pressure sustaining valves can be used in water transportation or distribution, generally to protect the upstream network against insufficient or even negative pressure.

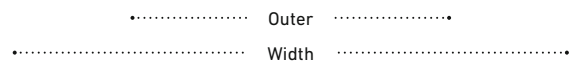

Dimensions and Weights

DIM (mm)	Outer	Length	Height	Width	Weight
DN50 (2")	107	121	270	269	5
DN80	142	135	305	304	6
DN100 (4")	162	155	325	324	7
DN150 (6")	218	205	380	380	11
DN200 (8")	273	298	430	460	21
DN250 (10")	328	348	515	515	33
DN300 (12")	381	398	55	570	49

Performance and Sizing

DIM (mm)	Kv Values	Cv Values
DN50 (2")	30	35
DN80	73	84
DN100 (4")	130	150
DN150 (6")	266	308
DN200 (8")	565	653
DN250 (10")	773	894
DN300 (12")	1004	1161

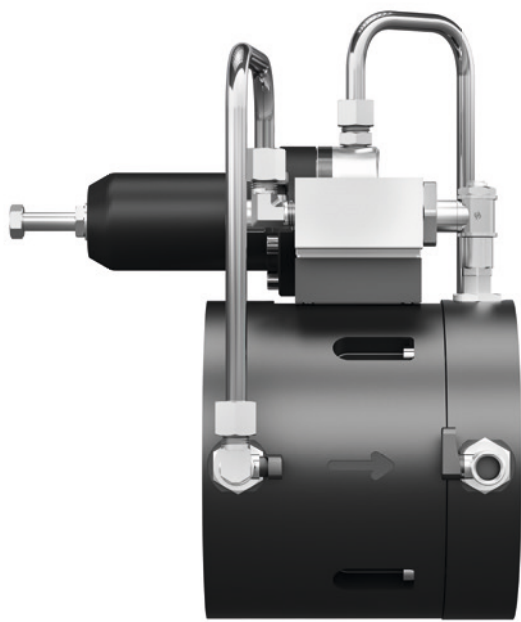

Height

Length

Application and Standards

Type	Details
Value Design	Axial Flow Design
Max. inlet Pressure	16 bar
Outlet Pressure Range	0.2 to 16 bar*
Medium	Water
Medium Temperature	0°C – 20°C**
Flange Standard	Metric, ANSI
Min. head lose	0.2 bar
Standards	EN1074

Materials

Component	Material
Valve Body	POM-C
Seat	POM-C
Actuator/Piston	POM-C
Sealing Matreial	EPDM
Components	Stainless Steel, Brass

* Depending on pilot valve setup

** Pressure derating applies for temperatures >20°C,
please contact your local GF expert

Next steps

In this brochure, you have received the most important information and technical details. But nothing replaces a personal conversation with an expert from GF Piping Systems.

It is all about your needs and how we can support you in your daily business challenges. If you have not already done so, make an appointment today. On the GF Piping Systems website, you will find specialized contact persons in your area. There you will also find further information on the product, including technical data sheets and operating instructions as well as relevant certificates and approvals.

- Appointment with an GF Piping Systems expert
- Advice on the benefits of the solution for you
- Information on reference applications
- Help with selection and calculations
- Support in all project phases

More information at:

gfps.com/neoflow

Worldwide at home

Our sales companies and representatives ensure local customer support in more than 100 countries.

www.gfps.com

Argentina / Southern South America

Georg Fischer Central Plastics Sudamérica S.R.L.
Buenos Aires / Argentina
Phone +54 11 4512 02 90
gfcentral.ps.ar@georgfischer.com
www.gfps.com/ar

Australia

Georg Fischer Pty Ltd
Riverwood NSW 2210
Phone +61 (0) 2 9502 8000
australia.ps@georgfischer.com
www.gfps.com/au

Austria

Georg Fischer Rohrleitungssysteme GmbH
3130 Herzogenburg
Phone +43 (0) 2782 856 43-0
austria.ps@georgfischer.com
www.gfps.com/at

Georg Fischer Fittings GmbH
3160 Traisen
Phone +43 (0) 2762 90300
fittings.ps@georgfischer.com
www.fittings.at

Belgium / Luxembourg

Georg Fischer NV/SA
1600 Sint-Pieters-Leeuw / Belgium
Phone +32 (0) 2 556 40 20
Fax +32 (0) 2 524 34 26
be.ps@georgfischer.com
www.gfps.com/be

Brazil

Georg Fischer Sist. de Tub. Ltda.
04571-020 São Paulo/SP
Phone +55 (0) 11 5525 1311
br.ps@georgfischer.com
www.gfps.com/br

Canada

Georg Fischer Piping Systems Ltd
Mississauga, ON L5T 2B2
Phone +1 (905) 670 8005
Fax +1 (905) 670 8513
ca.ps@georgfischer.com
www.gfps.com/ca

China

Georg Fischer Piping Systems Ltd
Shanghai 201319
Phone +86 21 3899 3899
china.ps@georgfischer.com
www.gfps.com/cn

Chinaust Plastics Corp. Ltd.
Songlindian, Zhuozhou city,
Hebei province, China, 072761
Phone +86 312 395 2000
Fax +86 312 365 2222
chinaust@chinaust.com
www.chinaust.com.cn

Denmark / Iceland

Georg Fischer A/S
2630 Taastrup / Denmark
Phone +45 (0) 70 22 19 75
info.dk.ps@georgfischer.com
www.gfps.com/dk

Finland

Georg Fischer AB
01510 Vantaa
Phone +358 (0) 9 586 58 25
Fax +358 (0) 9 586 58 29
info.fi.ps@georgfischer.com
www.gfps.com/fi

France

Georg Fischer SAS
95932 Roissy Charles de Gaulle Cedex
Phone +33 (0) 1 41 84 68 84
fr.ps@georgfischer.com
www.gfps.com/fr

Germany

Georg Fischer GmbH
73095 Albershausen
Phone +49 (0) 7161 302 0
info.de.ps@georgfischer.com
www.gfps.com/de

India

Georg Fischer Piping Systems Pvt. Ltd
400 083 Mumbai
Phone +91 22 4007 2000
Fax +91 22 4007 2020
branchoffice@georgfischer.com
www.gfps.com/in

Indonesia

PT Georg Fischer Indonesia
Karawang 41371, Jawa Barat
Phone +62 267 432 044
Fax +62 267 431 857
indonesia.ps@georgfischer.com
www.gfps.com/id

Italy

Georg Fischer S.p.A.
20864 Agrate Brianza (MB)
Phone +39 02 921 86 1
Fax +39 02 921 86 24 7
it.ps@georgfischer.com
www.gfps.com/it

Georg Fischer TPA S.r.l.
16012 Busalla (GE)
Phone +39 010 962 47 11
tpa.ps@georgfischer.com
www.gfps.com/it

Japan

Georg Fischer Ltd
530-0003 Osaka
Phone +81 (0) 6 6341 2451
jp.ps@georgfischer.com
www.gfps.com/jp

Korea

Georg Fischer Korea Co. Ltd
Unit 2501, U-Tower
120 Heungdeok Jungang-ro
(Yeongdeok-dong)
Giheung-gu, Yongin-si, Gyeonggi-do
Phone +82 31 8017 1450
Fax +82 31 217 1454
kor.ps@georgfischer.com
www.gfps.com/kr

Malaysia

George Fischer (M) Sdn. Bhd.
41200 Klang, Selangor Darul Ehsan
Phone +60 (0) 3 3122 5585
Fax +60 (0) 3 3122 5575
my.ps@georgfischer.com
www.gfps.com/my

Mexico / Northern Latin America

Georg Fischer S.A. de C.V.
CP 66603 Apodaca, Nuevo León / Mexico
Phone +52 (81) 1340 8586
Fax +52 (81) 1522 8906
mx.ps@georgfischer.com
www.gfps.com/mx

Middle East

Georg Fischer Piping Systems (Switzerland) Ltd
Dubai / United Arab Emirates
Phone +971 4 289 49 60
gcc.ps@georgfischer.com
www.gfps.com/int

Netherlands

Georg Fischer N.V.
8161 PA Epe
Phone +31 (0) 578 678 222
nl.ps@georgfischer.com
www.gfps.com/nl

Georg Fischer Waga N.V.
NL-8160 AG Epe
Phone +31 (0) 578 678 378
waga.ps@georgfischer.com
www.waga.nl

New Zealand

Georg Fischer Ltd
5018 Upper Hutt
Phone +04 527 9813
Fax +04 527 9834
nz.ps@georgfischer.com
www.gfps.com/nz

Norway

Georg Fischer AS
1351 Rud
Phone +47 67 18 29 00
no.ps@georgfischer.com
www.gfps.com/no

Poland

Georg Fischer Sp. z o.o.
05-090 Sekocin Nowy
Phone +48 (0) 22 31 31 0 50
poland.ps@georgfischer.com
www.gfps.com/pl

Romania

Georg Fischer Piping Systems (Switzerland) Ltd
020257 Bucharest - Sector 2
Phone +40 (0) 21 230 53 80
ro.ps@georgfischer.com
www.gfps.com/int

Russia

Georg Fischer Piping Systems (Switzerland) Ltd
Moscow 125040
Phone +7 495 748 11 44
ru.ps@georgfischer.com
www.gfps.com/ru

Singapore

George Fischer Pte Ltd
528 872 Singapore
Phone +65 6747 0611
Fax +65 6747 0577
sgp.ps@georgfischer.com
www.gfps.com/sg

Spain / Portugal

Georg Fischer S.A.
28046 Madrid / Spain
Phone +34 (0) 91 781 98 90
es.ps@georgfischer.com
www.gfps.com/es

Sweden

Georg Fischer AB
117 43 Stockholm
Phone +46 (0) 8 506 775 00
info.se.ps@georgfischer.com
www.gfps.com/se

Switzerland

Georg Fischer Rohrleitungssysteme (Schweiz) AG
8201 Schaffhausen
Phone +41 (0) 52 631 3026
ch.ps@georgfischer.com
www.gfps.com/ch

Taiwan

Georg Fischer Co. Ltd
San Chung Dist., New Taipei City
Phone +886 2 8512 2822
Fax +886 2 8512 2823
www.gfps.com/tw

United Kingdom / Ireland

Georg Fischer Sales Limited
Conventry, CV2 2ST / United Kingdom
Phone +44 (0) 2476 535 535
uk.ps@georgfischer.com
www.gfps.com/uk

USA / Caribbean

Georg Fischer LLC
92618 Irvine, CA / USA
Phone +1 714 731 88 00
Fax +1 714 731 62 01
us.ps@georgfischer.com
www.gfps.com/us

Georg Fischer Central Plastics LLC
Shawnee, OK 74801 / USA
Phone +1 (405) 273 63 02
gfcentral.ps@georgfischer.com
www.centralplastics.com

Vietnam

George Fischer Pte Ltd
Representative Office
Ho Chi Minh City
Phone +84 28 3948 4000
Fax +84 28 3948 4010
sgp.ps@georgfischer.com
www.gfps.com/vn

International

Georg Fischer Piping Systems (Switzerland) Ltd
8201 Schaffhausen / Switzerland
Phone +41 (0) 52 631 3003
Fax +41 (0) 52 631 2893
info.export@georgfischer.com
www.gfps.com/int

The information and technical data (altogether "Data") herein are not binding, unless explicitly confirmed in writing. The Data neither constitutes any expressed, implied or warranted characteristics, nor guaranteed properties or a guaranteed durability. All Data is subject to modification. The General Terms and Conditions of Sale of Georg Fischer Piping Systems apply.