



Luna Machinery

Australia



**When Performance and Service Counts
Nobody does it better**



1300 586 228

www.lunamachineryaustralia.com.au

Prices & Specifications are subject to change.



Luna is an Australian-owned Company, providing high-quality Aluminium and uPVC machinery to the Australian manufacturing sector. With over four decades of experience, we distribute equipment nationwide and offer bespoke customisation and local manufactured accessories through our Sydney-based workshop to meet our specific client needs.

By collaborating with international suppliers, we ensure our machines are rugged enough for unique local conditions.

Our comprehensive service model focuses on enhancing operational efficiency and driving growth for businesses across the country.

We are well placed to either get your new business up and operational or support you to deliver stronger growth and efficiency in your existing business with our specially selected machines.

In addition to our machine range, we provide exceptional ongoing service support with a selection of roller conveyor & length stop systems, router cutters, saw blades, spray mist lubricants & spare parts ex stock & all at affordable prices.

U5/24 Garling Road
Kings Park NSW 2148, Australia
+61 (02) 9676 5114
Email: sales@lunamac.com.au
www.lunamachineryaustralia.com.au

Single Head KD Series Mitre Saws

Luna Machinery has the largest range of single head mitre saws for aluminium in Australia. With access to such a large range we can find the right saw for you. From small 300mm to 400mm, mitre and compound.

Ideal for commercial and industrial aluminium and uPVC cutting.

The ergonomic handle design helps to reduce operator fatigue improving safety and efficiency. The integrated on/off switch also makes starting and stopping the machine much faster and safer.



KD400M/3



Optional Off Cut Clamp

Part Number	Equipment Description	Price Ex GST
KD350M/3	350mm dia blade, 2.2kW 415V motor, 2 Manual clamps	\$ 3,590.00+GST
KD350PS/3	Cut up to 180mm wide, 125mm high, 3 Pneumatic clamps, spray mist & stand	\$ 5,290.00+GST
KD400M/3	400mm dia blade, 2.2kW 415V motor, 2 Manual clamps	\$ 4,090.00+GST
KD400PS/3	Cut up to 205mm wide, 135mm high, 3 Pneumatic clamps, spray mist & stand	\$ 5,790.00+GST

Part Number	Optional Accessories	Price Ex GST
KD350/400/0000	230/240V 2.2kW 15Amp Single phase motor	\$ 300.00+GST
AC LUNA OCC	Luna Off Cut Clamp, for small pieces.	\$ 150.00+GST

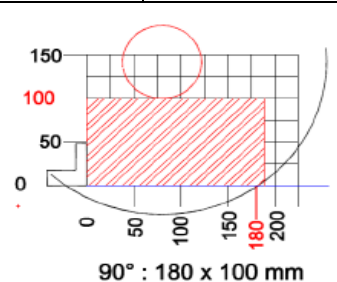
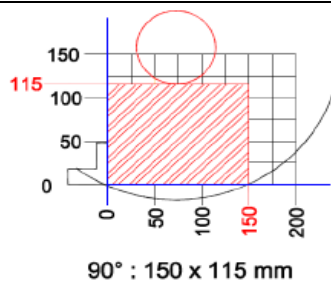
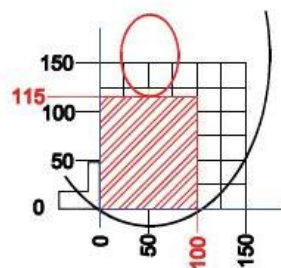
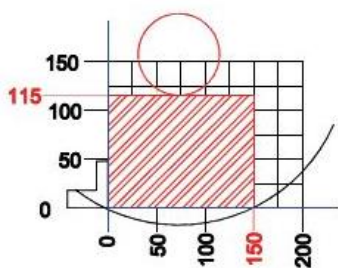

90° : 150 x 115 mm

90° : 180 x 100 mm

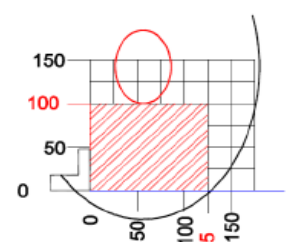
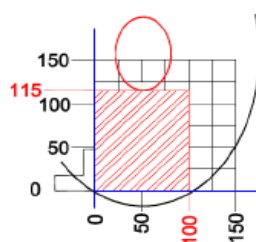
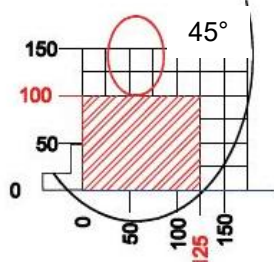
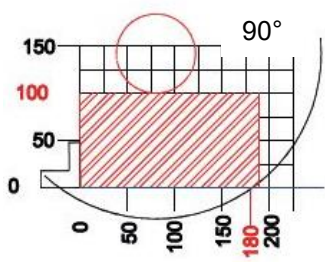

45° : 100 x 115 mm

45° : 125 x 100 mm

KD350 Cut Chart

KD400 Cut Chart

Single Head ACK Series Up-Cut Saws

Luna Machinery's has a large range of saws for aluminium manufacturing in Australia. Our up-cut saws range from 420mm to 700mm diameter. Ideal for large commercial and industrial aluminium, timber and uPVC sections.

Both horizontal and vertical clamping. Advanced safety features include electrical cut out on access panels, hood switches, two hand operation, tunnel guards and enclosed hood with LED lighting. All saws supplied with spray mist cooling, adjustable clamp pressure and air duster gun.



ACK700



ACK550 Horizontal and Vertical Clamps

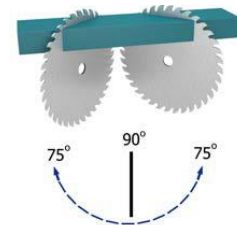

Wide angle range 75°, 60°, 45°, 30°, 22.5°, 15°, 90°
Positive Locating Points



Swarf extraction outlets



Hood Safety Switches

Part Number	Equipment Description	Price Ex GST
ACK420NPS	2.2kW 415V motor, 420mm blade, cut up to 140mm high, 200mm wide	\$ 9,990.00+GST
ACK420HNPS	2.2kW 415V motor, 420mm blade, cut up to 140mm high, 200mm wide, pneumatic hood	\$ 11,490.00+GST
ACK550PS	4.0kW 415V motor, 550mm blade, cut up to 200mm high, 330mm wide, pneumatic hood	\$ 16,900.00+GST
ACK700PS	4.0kW 415V motor, 700mm blade, cut up to 260mm high, 420mm wide, pneumatic hood	\$ 24,900.00+GST

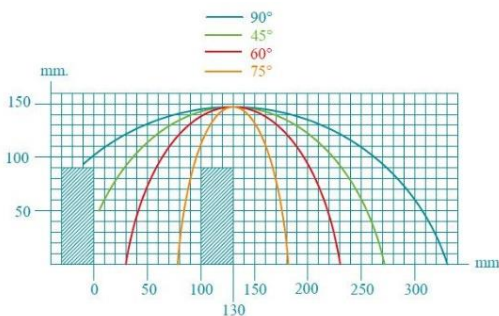

ACK420

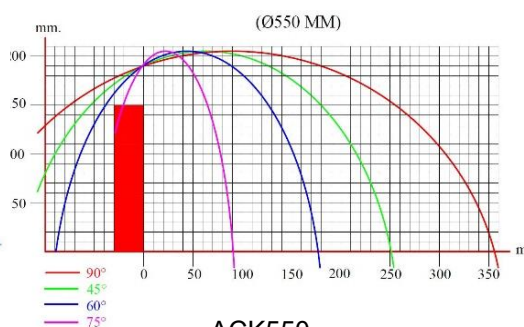

ACK550

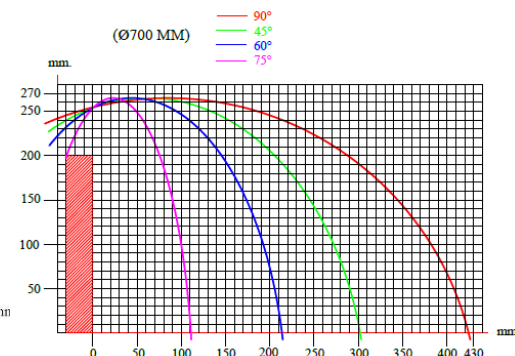

ACK700

V – Cut Double Mitre Saws

V-Cut Double Mitre Saw is the ideal machine for cutting Aluminium or Timber mitred frames.

Two blades fixed at 45 degrees guarantee a perfect mitre every time.

The most efficient way to cut Flyscreens, Security Doors, Awning windows and Picture Frames.

If you are still using a single head drop saw to cut your mitres and wish to increase the quality and quantity of your output then a V-Cut Double Mitre Saw is the machine is for you.



1 TAKE ONE SECTION:



2 PRECISION-CUT INTO 4 PIECES – time taken one minute



3 PERFECT MITRED CORNERS READY FOR ASSEMBLY



The close configuration of the blades minimises offcut and waste

Part Number	Equipment Description	Price Ex GST
SA 45	355mm blades, 1.5kW motors, 100mm high x 100mm wide cutting capacity	\$ 13,990.00 + GST
VK 420	420mm blades, 2.2kW motors, 230mm high x 110mm wide cutting capacity	\$ 17,900.00 + GST

Luna SA 45 Flyscreen Security Door Package

Part Number	Description
SA 45	V-Cut Mitre Saw, twin 355mm blades, 2 hand safety control
CK 4500	4.5 Metre infeed conveyor kit, with vertical guide rollers
CK 3000	3.0 Metre outfeed conveyor kit
LSMD 3.0	3.0 Metre Digital maxi measuring stop

\$ 15,900.00 + GST



Automatic Double Mitre Saws

If you're after fast and accurate cutting, a double mitre saw is the way to go. We have an extensive range of double mitre saws to suit your requirements. From manual to full CNC machines. From 400mm up to 600mm dia blades. All with adjustable hydraulic feed, two hand safety operation, spraymist blade lubrication, horizontal and vertical clamps ensure your material is cut right the first time. Reduce time and waste with a computerised double mitre saw.



DC 421PBSU

- Our Automatic saws feature;
- 1) Manual cutting
 - 2) Auto feed repetitive cutting
 - 3) Download your cutting list via Ethernet, WiFi or USB
 - 4) Import in Microsoft mdb or csv Format

Part Number	Equipment Description	Price Ex GST
DC 421PSD	420mm blade, 2.2kW motors 415V	PLC Controller \$ 44,500.00
DC 421PBSU	Cut capacity 268mm high x 158mm wide @90° 192mm high x 158mm wide @45°	CNC Controller \$ 49,500.00
DC 550PB	550mm blade, 4.0kW motors 415V	CNC Controller \$ 74,900.00
DC 550SK	Cut capacity 365mm high x 200mm wide @90° 262mm high x 200mm wide @45°	CNC Controller \$ 89,000.00
CDC 600	600mm blade, 4.0kW motors 415V	CNC Controller \$ 124,000.00
	Cut capacity 210mm high x 470mm wide @90° 210mm high x 330mm wide @45°	

Part Number	Optional Accessories	Price Ex GST
DM525A	Swarf extraction kit with integrated auto start	\$ 1,790.00
CK 6000	Infeed Conveyor	\$ 1,050.00



Notching Saws

Designed for precise 90 degree end notching. Suitable for all end notch cutouts in Sashes, Frames, Mullions and Transom Profiles. Perfect for Curtain walls, Skylights and Greenhouse manufacturing. The VK425 is one the largest capacity Notching Saws on the market, at a very affordable price.

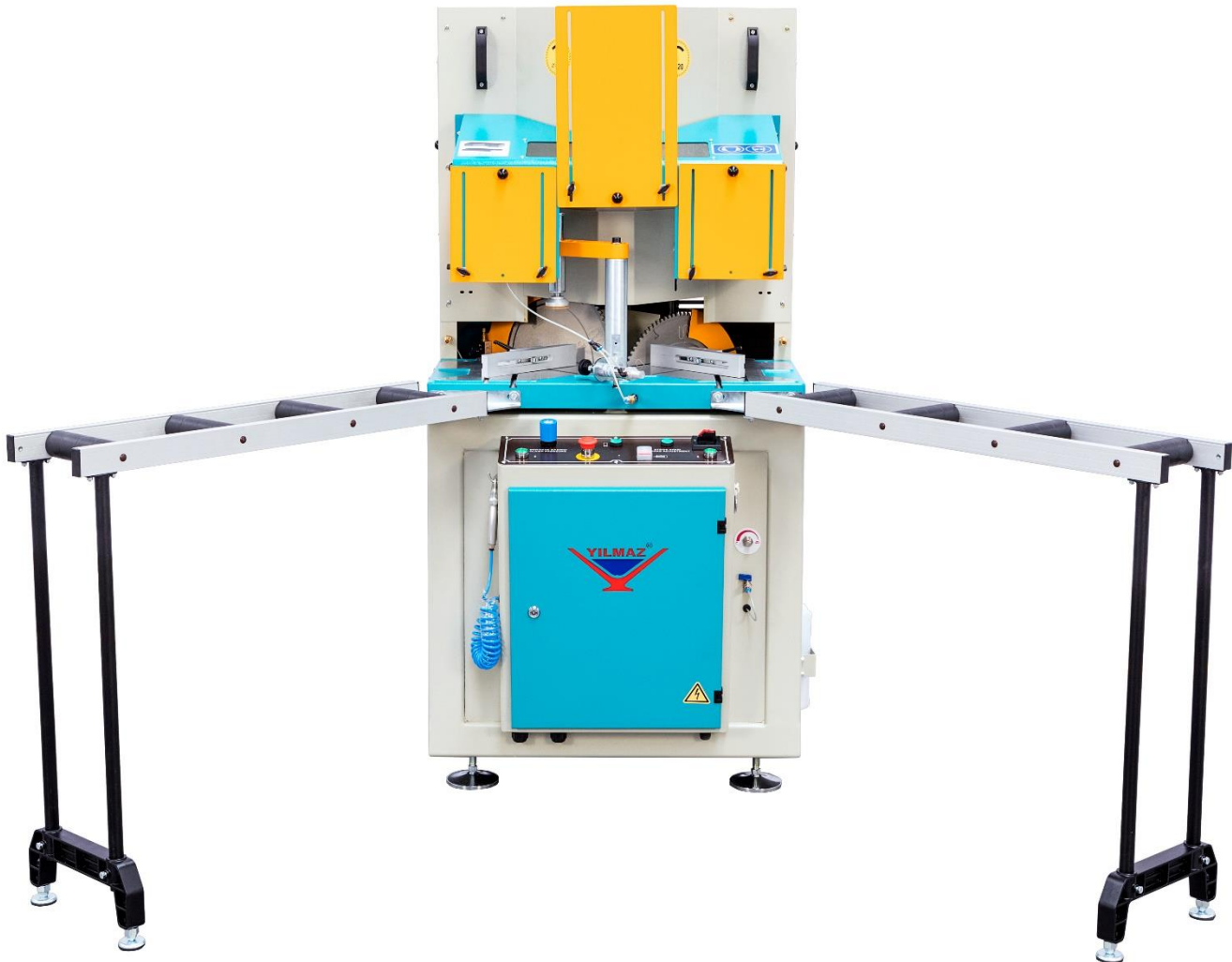

Part Number	Equipment Description	Height	Depth	Price Ext GST
VK425	2 x 2.2kW 415V motors, 2 x 420mm blades	230mm	150mm	\$ 18,900.00
SNM 560 M	2 x 2.2kW 415V motors, 2 x 550mm blades	205mm	185mm	\$ 49,000.00
SNM 560 SRV	2 x 2.2kW 415V motors, 2 x 550mm blades CNC	205mm	185mm	\$ 73,900.00



Single Head Back Cutting Mitre Saws

Luna back cutting saws feature large diameter blades with the ability to rotate from 90 degrees to 22.5 degrees both left and right, fast and easily, at the press of a button.

Suitable for cutting large sections requiring regular accurate angle changes.

Two hand operation and automatic hood makes Luna backing cutting saws one of the safest saws to use.



Part Number	Equipment Description	Price Ex GST
Bifra 550A	550mm blade, 1.85kW 3phase 415V Motor, 2 horizontal clamps 325mm H x 180mm W Cutting Capacity @90° 230mm H x 180mm W Cutting Capacity @45° 100mm H x 180mm W Cutting Capacity @20°	TBA
Ronda 700	700mm blade, 2.2kW 3 phase 415V Motor, 2 horizontal clamps 365mm H x 250mm W Cutting Capacity @90° 260mm H x 250mm W Cutting Capacity @45° 140mm H x 250mm W Cutting Capacity @20°	TBA



Compound Mitre Saws

Our range of compound mitre saws start at the small portable 300mm KD308 and go all the way up to the 650mm Fully CNC controlled CMPE 65.

If you're after a saw for compound cutting or bevel cutting we will have the right saw for you.



RYK 420



KD308PS/1



40MP/3

Part Number	Equipment Description	Price Ex GST
KD308PS/1	300mm, 800W 240V motor, 65mm high x 119mm wide cutting capacity	\$ 2,990.00 + GST
40MP/3	400mm, 2.2kW 415V motor, 125mm high x 190mm wide cutting capacity	\$ 8,990.00 + GST
RYK420	420mm, 2.2kW 415V motor, 170mm high x 410mm wide cutting capacity	\$ 14,490.00 + GST
CMPE 65	650mm, 5.5kW 415V motor, 230mm high x 400mm wide cutting capacity	\$ 79,900.00 + GST

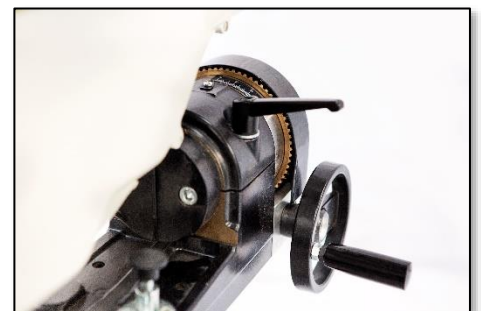
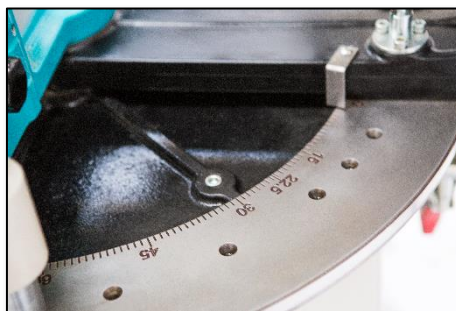

Copy Routers

Luna Machinery has an extensive range of Manual Copy Routers for cutting out slots and locks in both Aluminium and uPVC. From entry level options, to large capacity heavy duty models, all at affordable prices.

Our copy routers come standard with clamps and spraymist lubrication.

All our copy routers are supplied with a Lockwood template and a minimum 2 copy pins.

Quick change template increases efficiency and versatility.

We also stock a large range of router bits for your copy router and can design custom templates for you.



FR221PS/1



FR223MS/1



Two Adjustable Tracing Pins

Part Number	Equipment Description	Price Ex GST
FR223MS/1	750W 240V motor, max slot 270 x 110mm, height 110mm, 2 manual clamps	\$ 3,490.00 + GST
FR223PS/1	750W 240V motor, max slot 270 x 110mm, height 110mm, 2 pneumatic clamps	\$ 3,990.00 + GST
FR221PS/1	750W 240V motor, max slot 290 x 110mm, height 120mm, 2 pneumatic clamps	\$ 4,990.00 + GST

Part Number	Optional Accessories	Price Ex GST
MKN150	1.5 Metre infeed or out feed conveyor, with measuring stop	\$ 350.00ea + GST



Template for Lockwood 3580

Large Capacity Copy Routers

Our large capacity copy routers come with variable speed motors and allow you to machine 3 surfaces without unclamping the material. This reduces manufacturing time and the risk for scratching or marking the extrusion.

The CRM301 has a rotating table and is perfect for the largest of extrusions.
The CRM250 has 3 motors, one on each Axis.



Part Number	Equipment Description	Price Ex GST
CRM250S/1	3 x 1.1kW 240V motors, maximum slot x 110mm, height 225mm, 2 horizontal clamps, 2 vertical clamps, 2 templates, 4 adjustable pin locators	\$ 17,490.00 + GST



CNC Routers NCR

Our NCR CNC copy routers come in 3 and 4 Axis allowing you to machine 1 or 4 surfaces without unclamping the material. This reduces manufacturing time and the risk for scratching or marking the extrusion.

The NCR300 has a rotating table perfect for machining all 4 sides of the extrusion. this single head copy router has the ability to program X, Y, Z and C coordinates with 4 axis servo-controlled motors. It is used for the processing of slots for locks, drilling handles, hinges and water drain slot on uPVC and aluminium profiles, this means no more templates.

Alternatively, the cost effect NCR200 3 Axis machining, just the top surface.



Part Number	Equipment Description	Price Ex GST
NCR200	4.4kW 415V motor, maximum slot 300mm x 150mm, height 110mm 2 horizontal clamps	\$ 39,900.00 + GST
NCR300	6.5kW 415V motor, maximum slot 300mm x 120mm, height 115mm 2 horizontal clamps, rotating table 0°/90°/180°/270°	\$ 59,900.00 + GST



Corner Crimpers

Aluminium corner crimping machines offer the fastest and easiest way to assemble awning and sash windows. All of our crimpers feature 2 over head vertical pneumatics clamps ensuring the section is held tight. A retractable centre support makes loading the frames easy and safe. Profile support arms help keep the frame level. Scales on all settings make it easy to adjust the crimper from one section to another. From the entry level ATL211 Gamma crimper to the CNC 4 corner crimper, we have the right machine for your business.



ATL211 Gamma, suitable for all standard Australian window sections



CLM4S



KP130CNC



KP120

Part Number	Equipment Description	Price Ex GST
ATL211.3	4,000 kg Crimping force, pneumatic crimper	\$ 11,990.00 + GST
ATL211 CE	4,000 kg Crimping force, pneumatic crimper with CE guarding	\$ 12,490.00 + GST
WZJ-140H	8,000 kg Crimping force, 3 position hydraulic crimper	\$12,900.00 + GST
KP120	10,000 kg Crimping force, hydraulic crimper	\$ 17,900.00 + GST
KP130CNC	7,000 kg Crimping force, CNC, save and load settings	\$ 39,000.00 + GST
CLM4S	4 Corner CNC crimper, 550mm – 3,000mm	\$ 99,000.00 + GST

Part Number	Accessories Description	Price Ex GST
ATL5001	3mm Crimping tools	\$ 145.00 + GST
ATL5002	5mm Crimping tools	\$ 145.00 + GST
ATL5003	7mm Crimping tools	\$ 145.00 + GST
MKN100	1.0 Metre conveyor kit for ATL211 Gamma crimper	\$ 490.00 + GST
AC 980 013 108	Rapid P860 Aluminium Adhesive for extra strong corner fixing	\$ 29.00 + GST

End Mills

Luna Machinery offers both manual and semi-automatic End Mill Machines to suit all your fabricating needs. Suitable for Aluminium, uPVC and Timber. From Manual to Semi-Automatic machines.

Single profile to multi profile machines.

We can also provide you with tooling and customisation.



KM211PS/1



MEM128



KM215APS/3

Part Number	Equipment Description	Price Ex GST
KM211PS/1	800W 240V motor, Manual feed, milling stroke 150mm, depth 55mm 90mm height	\$ 3,990.00 + GST
KM215APS/3	800W 240V motor, Pneumatic feed, milling stroke 200mm, depth 55mm 90mm height	\$ 6,490.00 + GST
MEM128	2.2kW 415V motor, multi-profile end mill, up to 6 sections at once	\$ 21,900.00 + GST

Part Number	End Mill Tooling	Price Ex GST
AC EM C 120 3	120mm dia x 30/32mm bore x 3mm cutter	\$ 240.00 + GST
AC EM C 120 4	120mm dia x 30/32mm bore x 4mm cutter	\$ 240.00 + GST
AC EM C 120 5	120mm dia x 30/32mm bore x 5mm cutter	\$ 240.00 + GST
AC EM C 120 8	120mm dia x 30/32mm bore x 8mm cutter	\$ 275.00 + GST
AC EM C 120 10	120mm dia x 30/32mm bore x 10mm cutter	\$ 275.00 + GST
AC EM C 150 3	150mm dia x 30/32mm bore x 3mm cutter	\$ 280.00 + GST
AC EM C 150 4	150mm dia x 30/32mm bore x 4mm cutter	\$ 280.00 + GST
AC EM C 150 5	150mm dia x 30/32mm bore x 5mm cutter	\$ 320.00 + GST
AC EM C 150 6	150mm dia x 30/32mm bore x 6mm cutter	\$ 320.00 + GST
AC EM C 150 8	150mm dia x 30/32mm bore x 8mm cutter	\$ 390.00 + GST
AC EM C 150 10	150mm dia x 30/32mm bore x 10mm cutter	\$ 350.00 + GST
AC EM C 150 10R	150mm dia x 30/32mm bore x 10mm Radius cutter	\$ 430.00 + GST
AC EM C 150 12	150mm dia x 30/32mm bore x 12mm cutter	\$ 390.00 + GST
AC EM C 150 16	150mm dia x 30/32mm bore x 16mm cutter	\$ 430.00 + GST
AC EM C 150 25	150mm dia x 30/32mm bore x 25mm cutter	\$ 530.00 + GST
AC EM C 160 2.4	160mm dia x 30mm bore x 2.4mm cutter	\$ 220.00 + GST

Other Sizes available on request

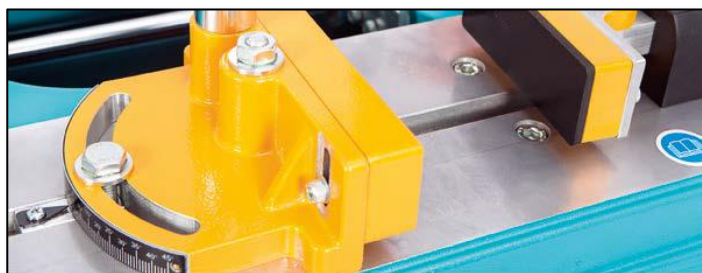

Roller Conveyors

Designed and made in Australia, Luna Aluminium Roller Conveyors are specifically designed to attach to all saws, copy routers, end mills and drill units.

Unique extruded aluminium frames make our conveyors lighter, straighter and easier to install than conventional steel gravity conveyors.

Adjustable PVC rollers with metal bearings minimise marking of your material and ensure a smooth even feed.

Roller Conveyor kits are available in continual lengths of 3.0 and 4.5 Metres. Custom kits can be configured to your specific requirements.

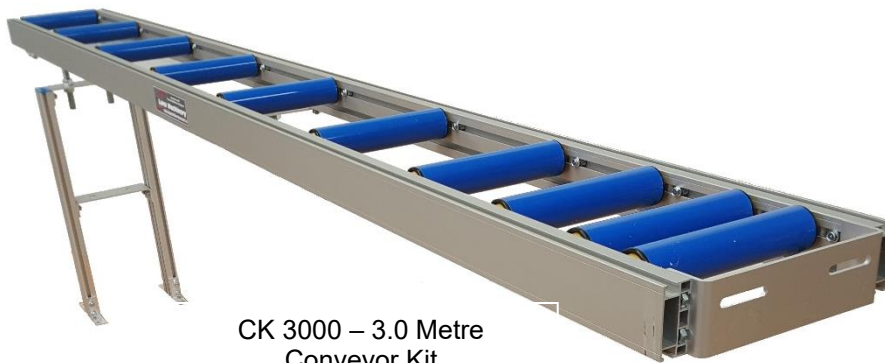

CK 3000 – 3.0 Metre
Conveyor Kit

Part Number	Conveyor Kits	Price Ex GST
CK 1500	1.5 Metre conveyor kit. Comprising one x 1.5 Metre conveyor, one adjustable stand, 300mm wide frame, five x 230mm wide rollers	\$ 430.00 + GST
CK 3000	3.0 Metre conveyor kit. Comprising one x 3.0 Metre conveyor, one adjustable stand, 300mm wide frame, ten x 230mm wide rollers	\$ 590.00 + GST
CK 4500	4.5 Metre conveyor kit. Comprising one x 4.5 Metre conveyor, two adjustable stands, 300mm wide frame, thirteen x 230mm rollers	\$ 890.00 + GST
CK 6000	6.0 Metre conveyor kit. Comprising two x 3.0 Metre conveyor, two adjustable stands, 300mm wide frame, seventeen x 230mm rollers	\$ 1,050.00 + GST

Part Number	Conveyor Components	Price Ex GST
C 1500	1.5 Metre conveyor section with five PVC rollers	\$ 250.00 + GST
C 3000	3.0 Metre conveyor section with ten PVC rollers	\$ 410.00 + GST
C 4500	4.5 Metre conveyor section with thirteen PVC rollers	\$ 530.00 + GST
CS 300	Adjustable support stand: 870mm to 1,000mm	\$ 180.00 + GST
T/INSERT	Solid table inserts 1.5 metre	\$ 120.00 + GST
V 132	Vertical guide roller for infeed conveyors	\$ 20.00 + GST
242 ROLLER	Additional rollers with adjustable holders	\$ 19.50 + GST

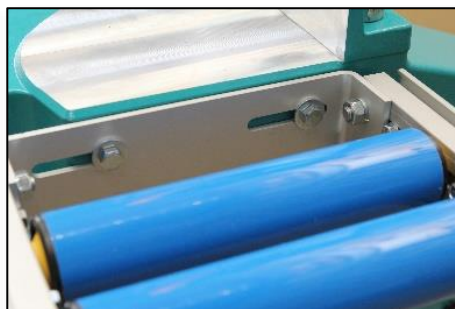

Extra Wide Roller Conveyors

Extra wide 460mm frame fitted with 390mm wide rollers.

Unique extruded aluminium frames make our conveyors lighter, straighter and easier to install than conventional steel gravity conveyors.

Adjustable PVC rollers with metal bearings minimise marking of your material and ensure a smooth even feed.

Roller Conveyor kits are available in continual lengths of 3.0 and 4.5 Metres. Custom kits can be configured to your specific requirements.



CK 4540 – 4.5 Metre Conveyor Kit

Part Number	Conveyor Kits	Price Ex GST
CK 1540	1.5 Metre conveyor kit. Comprising one x 1.5 Metre conveyor, one adjustable stand. 460mm wide frame, five x 390mm wide rollers	\$ 510.00 + GST
CK 3040	3.0 Metre conveyor kit. Comprising one x 3.0 Metre conveyor, one adjustable stand. 460mm wide frame, 390mm wide rollers	\$ 730.00 + GST
CK 4540	4.5 Metre conveyor kit. Comprising one x 4.5 Metre conveyor, two adjustable stands. 460mm wide frame, 390mm wide rollers	\$ 1,090.00 + GST
CK 6040	6.0 Metre conveyor kit. Comprising one x 6.0 Metre conveyor, two adjustable stands. 460mm wide frame, 390mm wide rollers	\$ 1,290.00 + GST

Part Number	Conveyor Components	Price Ex GST
C 1540	1.5 Metre conveyor section with five PVC Rollers	\$ 290.00 + GST
C 3040	3.0 Metre conveyor section with ten PVC Rollers	\$ 410.00 + GST
C 4540	4.5 Metre conveyor section with thirteen PVC Rollers	\$ 630.00 + GST
CS 460	Adjustable support stand, 870mm to 1,000mm	\$ 220.00 + GST
V 132	Vertical guide roller for infeed conveyors	\$ 20.00 + GST
394 ROLLER	Additional Roller with adjustable roller holders	\$ 29.50 + GST

Roller Conveyors with Steel Rollers

Designed and made in Australia, Luna Roller Conveyors are specifically designed to attach to all saws, copy routers, end mills and drill units.

Unique extruded aluminium frames make our conveyors lighter, straighter and easier to install than conventional steel frame gravity conveyors.

Adjustable Gal Steel rollers with metal bearings minimise marking of your material and ensure a smooth even feed.

Roller Conveyor kits are available in continual lengths of 3.0 and 4.5 Metres. Custom kits can be configured to your specific requirements.



CK S3000 – 3.0 Metre
Conveyor Kit

Part Number	Conveyor Kits	Price Ex GST
CK S1500	1.5 Metre conveyor kit. Comprising one x 1.5 Metre conveyor, one adjustable stand, 300mm wide frame, five x 230mm wide rollers	\$ 490.00 + GST
CK S3000	3.0 Metre conveyor kit. Comprising one x 3.0 Metre conveyor, one adjustable stand, 300mm wide frame, ten x 230mm wide rollers	\$ 630.00 + GST
CK S4500	4.5 Metre conveyor kit. Comprising one x 4.5 Metre conveyor, two adjustable stands, 300mm wide frame, thirteen x 230mm rollers	\$ 950.00 + GST
CK S6000	6.0 Metre conveyor kit. Comprising two x 3.0 Metre conveyor, two adjustable stands, 300mm wide frame, seventeen x 230mm rollers	\$ 1,090.00 + GST

Part Number	Conveyor Components	Price Ex GST
C S1500	1.5 Metre conveyor section with five Gal rollers	\$ 270.00 + GST
C S3000	3.0 Metre conveyor section with ten Gal rollers	\$ 470.00 + GST
C S4500	4.5 Metre conveyor section with thirteen Gal rollers	\$ 590.00 + GST
CS 300	Adjustable support stand; 870mm to 1,000mm	\$ 180.00 + GST
T/INSERT	Solid table inserts 1.5 metre	\$ 120.00 + GST
V 132	Vertical guide roller, PVC, for infeed conveyors	\$ 20.00 + GST
242S ROLLER	Additional Gal steel roller with adjustable holders	\$ 21.00 + GST

Wide Roller Conveyors Steel Rollers

Extra wide 465mm frame fitted with 380mm wide galvanised steel rollers.

Unique extruded aluminium frames make our conveyors lighter, straighter and easier to install than conventional steel gravity conveyors.

Adjustable Gal rollers with free running metal bearings minimise marking of your material and ensure a smooth even feed.

Roller Conveyor kits are available in continual lengths of 3.0 and 4.5 Metres.
Custom kits can be configured to your specific requirements.



CK S3040 – 3.0 Metre Conveyor Kit

Part Number	Conveyor Kits	Price Ex GST
CK S1540	1.5 Metre conveyor kit. Comprising one x 1.5 Metre conveyor, one adjustable stand. 465mm wide frame, 5 x 380mm wide rollers	\$ 530.00 + GST
CK S3040	3.0 Metre conveyor kit. Comprising one x 3.0 Metre conveyor, one adjustable stand. 465mm wide frame, 10 x 380mm wide rollers	\$ 730.00 + GST
CK S4540	4.5 Metre conveyor kit. Comprising one x 4.5 Metre conveyor, two adjustable stands. 465mm wide frame, 13 x 380mm wide rollers	\$ 1,190.00 + GST
CK S6040	6.0 Metre conveyor kit. Comprising one x 6.0 Metre conveyor, two adjustable stands. 465mm wide frame, 17 x 380mm wide rollers	\$ 1,290.00 + GST

Part Number	Conveyor Components	Price Ex GST
C 1540	1.5 Metre conveyor section with five Gal Rollers	\$ 310.00 + GST
C 3040	3.0 Metre conveyor section with ten Gal Rollers	\$ 510.00 + GST
C 4540	4.5 Metre conveyor section with thirteen Gal Rollers	\$ 750.00 + GST
CS 460	Adjustable support stand, 870mm to 1,000mm	\$ 220.00 + GST
V 132	Vertical guide roller, PVC, for infeed conveyors	\$ 20.00 + GST
394S ROLLER	Additional Gal Roller with adjustable roller holders	\$ 29.00 + GST

Length Stops – Manual & Digital

Luna Machinery heavy duty manual measuring stops are designed and made in Australia for the Australian market.

Easy to install, simple to adjust and calibrate. Able to be mounted on any conveyor system or bench top.

Left or right hand side operation for maximum flexibility. Magnifying sight glass and large 25mm Lufkin tape for fast and easy reading.

The heavy duty aluminium rail and heavy duty twin flag stop can handle rigorous daily use.

Mount multiple stops for even faster production.

The digital version features accuracy of +/- 0.1mm, large digital display, long battery life, absolute and increment modes.



Part Number	Manual Measuring Stops	Length	Price Ex GST
LSM 1.5	Manual measuring stop. Available in continual lengths up to 6.0 metres. Magnifying glass for easy reading and quick action locking handle. Supplied with one manual flip stop, 25mm metric tape & mounting bolts.	1.5 Metre	\$ 350.00 + GST
LSM 3.0		3.0 Metre	\$ 450.00 + GST
LSM 4.5		4.5 Metre	\$ 550.00 + GST
LSM 6.0		6.0 Metre	\$ 650.00 + GST

Part Number	Digital Manual Measuring Stops	Length	Price Ex GST
LSMD 1.5	Digital manual measuring stop. Available in continual lengths up to 6.0 metres. Large digital LCD for easy reading. Accuracy of +/- 0.1mm. Supplied with one Digital flip stop, 25mm metric tape and mounting bolts.	1.5 Metre	\$ 1,150.00 + GST
LSMD 2.0		2.0 Metre	\$ 1,250.00 + GST
LSMD 3.0		3.0 Metre	\$ 1,350.00 + GST
LSMD 4.5		4.5 Metre	\$ 1,450.00 + GST
LSMD 6.0		6.0 Metre	\$ 1,550.00 + GST

Part Number	Accessories	Price Ex GST
LSMF F/STOP	Additional Manual flip stop	\$ 190.00 + GST
LSMF F/STOP D	Additional Maxi Digital flip stop	\$ 790.00 + GST
LQSF F/STOP	Short piece stop Manual	\$ 290.00 + GST
LQSF F/STOP D	Short piece stop Digital	\$ 890.00 + GST
LSMF F/STOP E	Extended flag, for multiple piece cutting	\$ 290.00 + GST
LSMF F/STOP ED	Extended flag, for multiple piece cutting Digital	\$ 890.00 + GST



Auto Positioning Stops with Conveyors

Simple, easy to use and reliable measuring stop for all saws.

The HDL range of go-to-position measuring stops are servo controlled for fast accurate operation.

Windows touch screen interface. Electronic impact protection.

Solid steel conveyors with 2 adjustable height stands.

Optional label and barcode printer.

Transfer cutting list in CSV format, via SD Card.



Part Number	Laser Measuring Stops with Conveyor	Stroke	Length	Price Ex GST
HDL 4.0	Basic and simple to use touch screen interface. Electronic impact protection. Large easy to use interface. +/- 0.2mm accuracy.	3.6 Metre	4.0 Metre	\$ 13,900.00
HDL 7.0		6.6 Metre	7.0 Metre	\$ 16,900.00

Part Number	Accessories	Price Ex GST
Label	Auto label printer	\$ 1,500.00

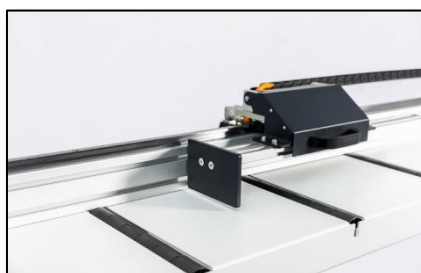

Standard HSS Router Bits

Luna HSS Router Cutters are specially designed for efficient routing of Aluminium and uPVC profiles. Made in Germany from high-quality High-Speed Steel and are designed to provide superior chip evacuation. For use in all manual and CNC routing machines. Always use LUNASOL coolant for a superb finish.
Suitable for all manual and CNC routing machines from 8,000 – 20,000rpm

Standard HSS Router Cutters

Part Number	A	B	C	D	E	Price Ex GST
RC 06836 5003	3	10		60	8mm	\$ 32.00 + GST
RC 06836 5004	4	12		60	8mm	\$ 32.00 + GST
RC 06836 5005	5	12		60	8mm	\$ 29.00 + GST
RC 06002 8005 CRN	5	12		60	8mm	\$ 32.00 + GST
RC 06836 5005 DLC	5	12		60	8mm	\$ 35.00 + GST
RC 08000 8255	5	25		80	8mm	\$ 39.00 + GST
RC 06836 5006	6	14		60	8mm	\$ 32.00 + GST
RC 06836 5007	7	14		60	8mm	\$ 32.00 + GST
RC 06836 5008	8	14		80	8mm	\$ 32.00 + GST
RC 06836 5010	10	14		80	8mm	\$ 39.00 + GST
RC 07836 5010	10	14		80	10mm	\$ 59.00 + GST

Long Series HSS Router Cutters

RC 06836 5050	5	14		120	8mm	\$ 49.00 + GST
RC 07000 8255	5	25		70	8mm	\$ 49.00 + GST
RC 08000 8258	8	25		80	8mm	\$ 39.00 + GST
RC 06836 5051	8	14		120	8mm	\$ 49.00 + GST
RC 07836 5025	10	14		120	10mm	\$ 59.00 + GST

Reduced Shank HSS Router Cutters

RC 09010 8004	4	16	42	90	8mm	\$ 39.00 + GST
RC 06836 5019	5	18	36	80	8mm	\$ 39.00 + GST
RC 09010 8005	5	16	45	90	8mm	\$ 39.00 + GST
RC 09010 8155	5	16	52	90	8mm	\$ 39.00 + GST
RC 02010 8005	5	14	35	120	8mm	\$ 59.00 + GST
RC 02010 8175	5	14	75	120	8mm	\$ 69.00 + GST
RC 06836 5023	6	14	35	80	8mm	\$ 39.00 + GST
RC 09010 8006	6	16	43	90	8mm	\$ 39.00 + GST
RC 08010 8007	7	14	45	90	8mm	\$ 49.00 + GST
RC 06836 5022	8	14	54	80	8mm	\$ 39.00 + GST
RC 02010 8008	8	14	90	120	8mm	\$ 59.00 + GST
RC 01011 0010	10	30	70	100	10mm	\$ 49.00 + GST

Water Slot HSS Router Cutters

RC 01100 8005	5	40		100	8mm	\$ 49.00 + GST
---------------	---	----	--	-----	-----	----------------

6mm Shank HSS Router Cutters

RC 06000 6003	3	12		60	6mm	\$ 29.00 + GST
RC 06000 6004	4	12		60	6mm	\$ 29.00 + GST
RC 06000 6005	5	12		60	6mm	\$ 29.00 + GST
RC 06000 6006	6	12		60	6mm	\$ 29.00 + GST

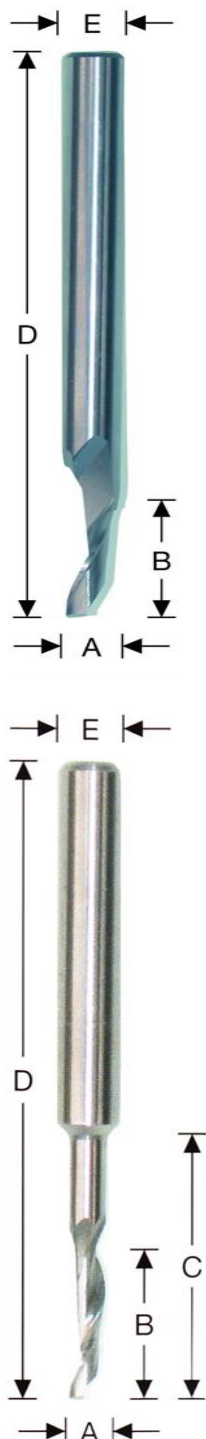

Special Router Bits

Milling Cutters HSS

Part Number	A	B	C	D	E	Price Ex GST
RC 08200 8008	8	14		80	8mm	\$ 49.00 + GST
RC 08200 8010	10	14		80	8mm	\$ 59.00 + GST
RC 08201 0010	10	45		95	10mm	\$ 69.00 + GST
RC 17836 6010	10	22	60	100	10mm	\$ 85.00 + GST

Special Steel Router Cutters

RC 16000 8005	5	12		60	8mm	\$ 39.00 + GST
RC 18000 8008	8	14		80	8mm	\$ 39.00 + GST
RC 06570 3005	5	11		65	8mm	\$ 49.00 + GST

Solid Carbide Cutters

Luna Solid Carbide Router Cutters offer longer and faster cutting than HSS. We recommend solid carbide cutters for CNC machines. Always use LUNASOL XL coolant for a superb finish and extended life. Machining speeds from 8,000 - 30,000rpm.

RC C05070 3003	3	12		50	3mm	\$ 65.00 + GST
RC C05070 6003	3	12		50	6mm	\$ 75.00 + GST
RC C06070 8003	3	20		60	8mm	\$ 85.00 + GST
RC C05070 4004	4	12		50	4mm	\$ 85.00 + GST
RC C07070 4040	4	12		70	4mm	\$ 75.00 + GST
RC C06070 8004	4	20		60	8mm	\$ 85.00 + GST
RC C07070 5050	5	12		70	5mm	\$ 75.00 + GST
RC C06070 6005	5	20		60	6mm	\$ 75.00 + GST
RC C06070 8005	5	20		60	8mm	\$ 85.00 + GST
RC C07070 6060	6	12		70	6mm	\$ 75.00 + GST
RC C06070 8006	6	16		60	8mm	\$ 85.00 + GST
RC C06070 8008	8	17		60	8mm	\$ 69.00 + GST
RC C06070 8009	8	22		60	8mm	\$ 69.00 + GST
RC C07070 0010	10	25		80	10mm	\$ 75.00 + GST
RC C09070 8510	10	50		90	8mm	\$ 129.00 + GST

Alucobond V Groove Cutters

RC V05437 2506 SC	10	90		70	10mm	\$ 210.00 + GST
RC V106598 PCD TIP	10	90		65	10mm	\$ 84.00 + GST
RC V125090 6 PCD TIP	12	90		50	6mm	\$ 199.00 + GST
RC V125090 8 PCD TIP	12	90		50	8mm	\$ 249.00 + GST

Counter Sink Bits

RC V205090 TCT	20	90		50	6mm	\$ 49.00 + GST
RC 303 004 120	12	51		102	12mm	\$ 19.00 + GST
RC 310 006 100	10	4			6mm	\$ 29.00 + GST
RC 310 008 124	12.4	4			8mm	\$ 32.00 + GST
RC 310 010 205	20.5	5			10mm	\$ 34.00 + GST

Hoffman/Dovetail Key

RC AZ130 0003	8	6		42	8mm	\$ 45.00 + GST
---------------	---	---	--	----	-----	----------------

uPVC Triple Drill Bits

RC 1SK04 0004	10	10		105	10MM	\$ 79.00 + GST
RC 1SK04 0005	13	13		110	13MM	\$ 89.00 + GST

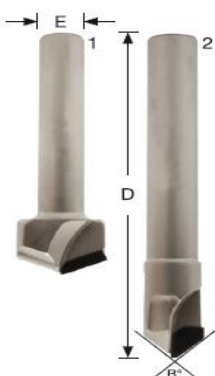
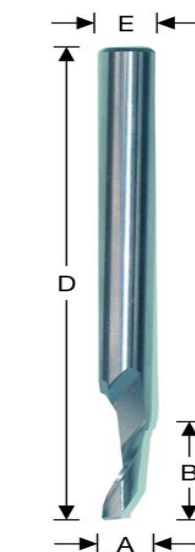
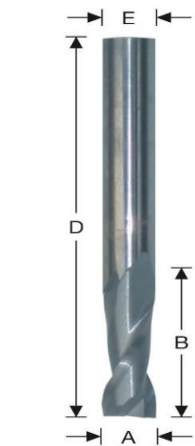

Schaffer Saw Blades



Luna Blades with Triple Chip Tooth design are ideal for all general aluminium, uPVC and non-ferrous metal cutting. They are constructed from the highest quality High Speed Steel and use Super hardened Tungsten Carbide for the teeth. They offer superior cut finish for aluminium and other non-ferrous metals. Due to the quality of materials and construction they offer improved blade life compared to other brands. We recommend the use of Luna spray mist systems & LUNASOL cutting fluid to maximise blade life & cut finish.

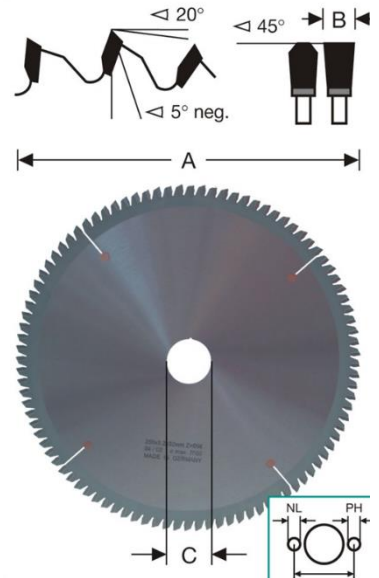

Part Number	A	B	C	Teeth	Rake	Price Ex GST
B 301 250S	250	3.2	30	80T	NEG	\$ 169.00 + GST
B 301 280S	280	3.2	32	88T	POS	\$ 179.00 + GST
B 301 300S	300	3.2	30	96T	NEG	\$ 189.00 + GST
B 301 330S	330	3.4	32	96T	NEG	\$ 229.00 + GST
B 301 350S	350	3.4	30	108T	NEG	\$ 239.00 + GST
B 301 380S	380	3.8	32	110T	NEG	\$ 289.00 + GST
B 301 400S	400	4.0	30/32	108T	NEG	\$ 279.00 + GST
B 301 420PS	420	4.0	30	120T	POS	\$ 359.00 + GST
B 301 450	450	4.4	30	108T	POS	\$ 450.00 + GST
B 301 551P	550	4.0	30	96T	NEG	\$ 649.00 + GST
B 301 550PS	550	4.4	30	128T	POS	\$ 529.00 + GST
B 301 600P	600	4.5	30	144T	POS	\$ 849.00 + GST
B 301 700PS	700	5.0	38	160T	POS	\$ 749.00 + GST

Kanefussa Premium Saw Blades



High Tech Carbide tipped blades with noise reduction for cutting Aluminium, Non Ferrous metals, timber and uPVC. Kanefussa blades offer superb cut finish and extra-long life. The very best in blade quality. Made in Japan.

Part Number	A	B	C	Teeth	Rake	Price Ex GST
BK 301 300	300	2.5/3.0	30	108T	POS	\$ 290.00 + GST
BK 301 355	355	2.5/3.0	30	120T	POS	\$ 399.00 + GST
BK 301 400	400	2.5/3.0	32	120T	POS	\$ 399.00 + GST
BK 301 420	420	2.5/3.0	32	120T	POS	\$ 429.00 + GST
BK 301 550	550	3.4/4.0	30	132T	POS	\$ 790.00 + GST
BK 301 700	700	4.6	38	120T	POS	\$ 990.00 + GST

Luna Machinery recommends the use of POSITIVE RAKE blades only on machines which have automatic blade feed. This includes double mitre saws, up cutting saws and back cutting saws. Machines with manual blade feed should only be fitted with NEGATIVE RAKE blades. Cutting Aluminium without Lubricant will cause the Aluminium to Cold Weld to the Teeth.

Lunasol Ultra

Our Improved formula Aluminium cutting fluid is a fully synthetic product designed to assure the cleanest cut possible when working with non-ferrous metals. Lunasol Ultra's unique scientific formula provides optimum cooling and lubrication properties. It is specially formulated for air operated spray-mist systems and can also be used in "Flood Cooling" applications and punching dies.

- Multi-metal Safe (including stainless steel)
- Lengthens blade life
- Biodegradable - does not contain petroleum-based oils
- Contains special corrosion inhibitors, will not rust or corrode
- Use for ferrous or non-ferrous metals
- Non flammable
- Refer; Material Safety Data Sheet (available upon request)
- Dilute 20 : 1 with water



Part Number	Description	Price Ex GST
C L/SU 1L	Lunasol Ultra 1 Litre concentrate	\$ 29.00 + GST
C L/SU 5L	Lunasol Ultra 5 Litre concentrate	\$ 79.00 + GST
C L/SU 20L	Lunasol Ultra 20 Litre concentrate	\$ 289.00 + GST

Lunasol XL

Lunasol XL is a superior coolant/cutting fluid for use in precision spray mist applicators and positive displacement pumps. It is designed to ensure the cleanest cut possible when working with Non-Ferrous Metals and Alloy Steel. Lunasol XL has a unique scientific formula providing optimum cooling and lubricating properties. Made in Germany to high specifications this coolant is specially formulated for high precision coolant pumps found on most **CNC** routing machines. Special "Anti Wear" additives are used to prolong tool life and improve cut finish. Designed to be used in micro-drop or high precision pumps.







Part Number	Description	Price Ex GST
C X/L 1L	XL High performance 1 Litre	\$ 39.00 + GST
C X/L 5L	XL High performance 5 Litre	\$ 195.00 + GST
C X/L 20L	XL High performance 20 Litre	\$ 590.00 + GST

Workshop Equipment

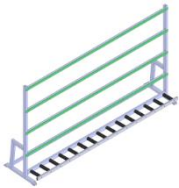
Part Number	Equipment Description	Price Ex GST
WB 4000 	Assembly Work Bench Fully Adjustable Assembly Table Length 2000mm - 4000mm, Width 1000mm – 2000mm PVC Inserts to prevent scratches Trays for tools & accessories Provision for Air Supply mounting Loading capacity : 350 kg	\$ 2,690.00 + GST
PT 1000 	Finished Product Trolley Moveable Transport Trolley Length 1500mm x Width 900mm x Height 1580mm Surfaces are covered with rubber to prevent scratching Loading capacity : 500 kg	\$ 1,090.00 + GST
GPT 1000 	Glass & Profile Trolley Moveable Glass & Profile Trolley Length 1500mm x Width 990mm x Height 1500mm Holds 7 x 140mm wide, with bottom rollers for easy loading Loading capacity : 300 kg	\$ 1,890.00 + GST
HP 1000 	Horizontal Profile Trolley Aluminium and PVC Extrusion Trolley Length 1500mm x Width 990mm x Height 1500mm 5 x 595mm long support racks, 235mm High Loading capacity : 350 kg	\$ 1290.00 + GST
PWB 4100 	Pneumatic Tilt Table Workbench Adjustable Lifting Table L 1700mm–2200mm, W 1800mm–3200mm Height 865mm Tilts to 70 degrees, Max Frame 3200mm x 2800mm Loading capacity : 350 kg	\$ 6,490.00 + GST
VP 1000 	Vertical Profile Trolley Aluminium and PVC Extrusion Trolley Length 1500mm x Width 990mm x Height 1500mm 10 Bays 105mm wide x 595mm deep x 240mm high Loading capacity : 500 kg	\$ 1,090.00 + GST
VP 2000 	Vertical Profile Trolley Double Sided Aluminium and PVC Extrusion Trolley Length 1540mm x Width 1440mm x Height 1800mm 2 x 10 Bays 105mm wide x 595mm deep x 240mm high Loading capacity : 600 kg	\$ 1,990.00 + GST
GT 1000 	Gasket Trolley Moveable Gasket Trolley 1500mm High Holds 4 gasket Rolls, Lockable Holders Lockable wheels Loading capacity : 300 kg	\$ 990.00 + GST

Workshop Equipment

Part Number	Equipment Description	Price Ex GST
RT 1000 	Rotating Table Rotating table for frame and sash assembly Easy foot pedal operation Adjustable arms : 700 -1,000 mm Height: 950 mm Loading capacity : 110 kg	\$ 990.00 + GST
WAS 1000 	Window Assembly Station Length 3000mm x Width 650mm x Height 1700mm with bottom rollers for easy loading Loading capacity : 500 kg	\$ 1,990.00 + GST
PC 4000 	Profile Trolley Used for carrying and storing vertical profiles Width 855mm x Length 4,000mm x Height 1,000mm Distance between sections: 765mm Length of holding bars: 275mm Loading capacity : 850kg	\$ 2,490.00 + GST
NSM 350 – 353 	Sash Assembly Station Used to assembly all Tilt and Turn hardware systems on various size window and door sash profiles, without tape measure and pencil, without the need for moulds and templates, provides speedy, high quality and standard assembly.	from \$ 25,000 + GST
GAS 301 	Glass Assembly Table Fast Glass Installation, 70° Inclined Working Platform, Ergonomic Use, Roller Surfaces.	\$ 16,000.00 + GST

Swarf Extractors

Keep your machine and workplace clean with a Luna Swarf Extractor. Improve safety by reducing slips and falls hazards.

- Specifically designed for aluminium
- Wet or dry applications
- Compact construction
- Castor wheels
- High air flow capacity
- Induction motor
- Quick release bag straps
- Woven Fabricon collection bag for aluminium

DM525A/3



Part Number	Equipment Description	Price Ex GST
DM515T/1	1,600 cfm, 1.5kW Motor 240V, 2 x 100mm inlets, Cloth bag	\$ 1,290.00 + GST
DM515A/1	1,600 cfm, 1.5kW Motor 240V, 2 x 100mm inlets, Fabricon bag	\$ 1,390.00 + GST
DM515T/3	1,600 cfm, 1.5kW Motor 415V, 2 x 100mm inlets, Cloth bag	\$ 1,290.00 + GST
DM515A/3	1,600 cfm, 1.5kW Motor 415V, 2 x 100mm inlets, Fabricon bag	\$ 1,390.00 + GST
DM525T/3	1,800 cfm, 2.2kW Motor, 2 x 100mm inlets, Cloth bag	\$ 1,490.00 + GST
DM525A/3	1,800 cfm, 2.2kW Motor, 2 x 100mm inlets, Fabricon bag	\$ 1,590.00 + GST
DM535T/3	2,550 cfm, 3.7kW Motor, 4 x 100mm inlets, Twin Cloth bags	\$ 2,590.00 + GST
DM535A/3	2,550 cfm, 3.7kW Motor, 4 x 100mm inlets, Twin Fabricon bags	\$ 2,690.00 + GST

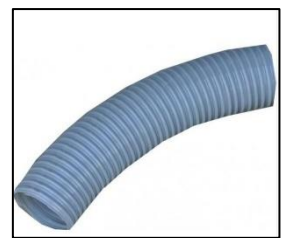





DM515T

Part Number	Equipment Description	Price Ex GST
ACE HC63	50 – 70mm Hose Clamp	\$ 6.00 + GST
ACE HC75	70 - 90mm Hose Clamp	\$ 7.00 + GST
ACE HC100	90 – 110mm Hose Clamp	\$ 7.00 + GST
ACE DM1026	100mm – 63mm Reducer	\$ 25.00 + GST
ACE DM1014	75mm Y Connector	\$ 19.00 + GST
ACE DM1015	100mm Y Connector	\$ 19.00 + GST
ACE DM1006	75mm Gate	\$ 25.00 + GST
ACE DM1007	100mm Gate	\$ 29.00 + GST
ACE DM1003	Floor Vacuum cleaner outlet	\$ 29.00 + GST
ACE HS 02.5	63mm Extractor Hose	\$ 14.00 + GST
ACE HS 03	75mm Extractor Hose	\$ 18.00 + GST
ACE HS 04	100mm Extractor Hose	\$ 23.00 + GST

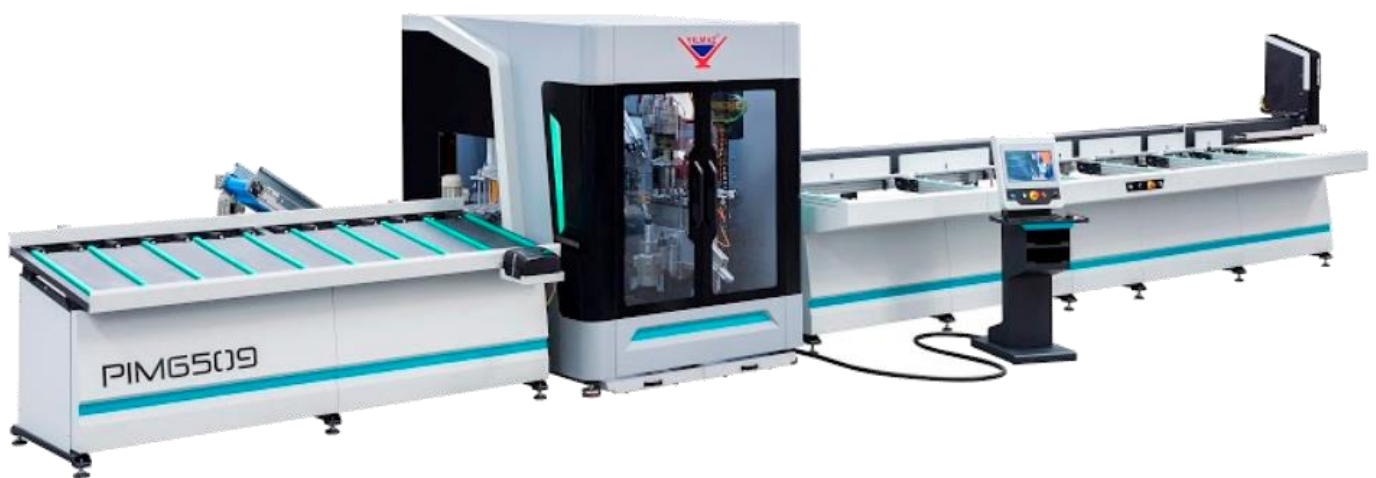
uPVC Machining Centres

For fast, accurate and reliable cutting of uPVC and Aluminium profiles, you can't go past a machining centre. Load up to 10 profiles at once, 6.5 metres in length. Available with optional barcode printing. Easy to use computer interface.



Part Number	Equipment Description	Price Ex GST
PCC 6505 	500mm saw blade, 5 – Axis CNC. Load up to 10 profiles. Average cut time 12-16 sec per piece. Cut any angle between 45 and 135 Degrees.	From \$ 165,000 + GST
PIM 6508 	500mm saw blade, 8 – Axis CNC. Load up to 10 profiles. Cut any angle between 30 and 150 Degrees. Includes drill and routing units.	From \$ 239,000 + GST
PIM 6509 	550mm saw blade, 8 – Axis CNC. Load up top 7 profiles at once. Cut any between 30 and 150 Degrees. Includes drilling and routing units.	From \$ 259,000 + GST

uPVC Welding Machines







Luna Machinery has a large range of quality Welders for uPVC Profiles and the local technical experience to back them up. 2.0mm Standard welds or 0.2mm Seamless. All made in Europe to CE standards, with local backup and support.

Part Number	Equipment Description	Price Ex GST
TK 500 	Single Head Portable Welder <ul style="list-style-type: none"> • 140mm weld height • 0.2mm – 2.0mm Weld • 90 Degree • Adjustable melting and welding time 	\$ 4,900.00 + GST
TK 503 	Single Corner Welding Machine <ul style="list-style-type: none"> • 165mm weld height • 0.2mm – 2.0mm Weld • 30-180 Degree • Adjustable melting and welding time 	\$ 7,490.00 + GST
TK 505 	Single Welding Machine <ul style="list-style-type: none"> • 180mm weld height • 0.2mm – 2.0mm Weld • 30-180 Degree • Adjustable melting and welding time 	\$ 9,900.00 + GST
DK 502 Seamless 	Seamless Twin head Welder <ul style="list-style-type: none"> • 180mm weld height • 0.2mm – 2.0mm Weld • 30-180 Degree • Min 340mm, Max 3530mm frame • Adjustable melting and welding time 	\$ 24,900.00 + GST
DK 540 	Four Head Welder <ul style="list-style-type: none"> • 180mm weld height • 0.2mm – 2.0mm Weld • 90 Degree • Min 400mm, Max 2700x3100mm frame • Adjustable melting and welding time 	\$ 99,000.00 + GST
SA 250 	Cooling Unit <ul style="list-style-type: none"> • Option for DK 540 • 2000mm x 3000mm 	\$ 12,900.00 + GST
CS 240 	Gasket Pressing System <ul style="list-style-type: none"> • Option for DK 540 	\$ 15,900.00 + GST
MCA 801 	Automatic Mullion Joining Machine <ul style="list-style-type: none"> • 30mm, 12,000RPM • 2 Automatic scree feeds • Foot pedal operation • Adjustable screw force • Max Steel 2.5mm • Screw height adjustment • Screw feed speed 1.7 Seconds 	P.O.A

uPVC Corner Cleaning Machines

Luna Machinery has a large range of quality Welders for uPVC Profiles and the local technical experience to back them up.







Part Number	Equipment Description	Price Ex GST
MVC 130 	For corner cleaning of Transom, Cruciform, Crucifix and Cross Joint welds. 130mm Max height. PLC Controller.	P.O.A
CA 601 	90 degree welds, up to 180mm high, quick Manual tool change. Automatic start and stop feature.	\$ 9,990.00 + GST
CA 603 	90 degree weld cleaning, up to 180mm high, 4 cutter stacks. Quick tool change. Automatic start and stop feature. Quick and easy selection of cutter stack.	\$ 12,990.00 + GST
CNC 608 	90 degree weld cleaning, up to 180mm high, 2 Axis/Servo Motors CNC 6500 profile memory. Process 210-230 window frames in 8 hours	\$ 59,000.00 + GST
CNC 610 	90 degree weld cleaning, up to 180mm high, 4 Axis/Servo motors CNC. Independent controller for the top and bottom cleaning knives. 6500 profile memory Process 260-280 window frames in 8 hours	\$ 79,000.00 + GST
SA 260 	Rotating table for CNC 608 and CNC 610	\$ 29,000.00 + GST

uPVC Routing & WaterSlotting Machines

Luna Machinery has a large range of quality Routers and Water Slotters for uPVC Profiles and the local technical experience to back them up.







Part Number	Equipment Description	Price Ex GST
FR 225S 	<ul style="list-style-type: none"> • Manual router and Triple drill unit • Equipped with tools for triple drilling • 2x left and right profile stops • 2x horizontal clamps 	\$ 6,900.00 + GST
FR 226S 	<ul style="list-style-type: none"> • Manual router and Automatic Triple Drill unit • Equipped with tools for triple drilling mechanism • 2 x left and right profile stops • 2 x pneumatic horizontal clamps 	\$ 7,900.00 + GST
CRM 201S 	<ul style="list-style-type: none"> • Manual router and Automatic Triple Drill unit • Maximum slot 300 x 130mm, Height 135mm • Template Size 500 x 150mm (Usable area 460 x 140mm) • 2 x left and right profile stops • 2 x horizontal clamps. 2 x vertical clamps 	\$ 12,990.00 + GST
ST 264 	<ul style="list-style-type: none"> • 3 x 0.55kW (0.7HP) 240V 1 phase Motor 18000rpm • Maximum profile dimension: H: 115 x W: 100 mm • Two (2) Vertical Pneumatic Clamps • Pneumatic spray mist with One (1) litre coolant • Air duster gun, Air Pressure Regulator & Lubrication Unit 	\$ 8,950.00 + GST

uPVC Reinforcement Screw Machines

For automatic screwing of the steel reinforcement bars in uPVC profiles. Single and dual head machines are available and full assembly benches.



Part Number	Equipment Description	Price Ex GST
SM 201 	Single Head Machine <ul style="list-style-type: none"> • Automatic screw feeding unit • Feed speed 1.7 sec, max 2.0mm • Foot Pedal operation • Adjustable screw force • Automatic stopping • Adjustable screw height • Automatic clamping 	\$ 12,900.00 + GST
SM 201 SD 	Dual Head Machine <ul style="list-style-type: none"> • Automatic screw feeding unit • Feed speed 1.7 sec, max 2.5 mm • Foot Pedal operation • Adjustable screw force • Automatic stopping • Adjustable screw height • Automatic clamping 	P.O.A
SM 206 	Dual Head Machine <ul style="list-style-type: none"> • Twin automatic screw feeding unit • Height adjustment sensor • Feed speed 1.7 sec, max 2.0mm • Foot Pedal operation • Adjustable screw force • Automatic stopping • Adjustable screw height • Automatic clamping 	\$ 39,000.00 + GST
NSM 350 – 353 	Sash Assembly Station <ul style="list-style-type: none"> • Assembly table for window sash hardware • Over head storage • Centring device, • Manual drill, steel shear, • Automatic screw driver and drills • Template 	from \$ 25,000.00 + GST
SM 1000 	<ul style="list-style-type: none"> • Automatic conveying of PVC profiles • Automatic profile length detection • 2 servo controlled screwing heads • Outfeed magazine • Screwing speed: 2.5-3 sec./pc approx. for single head • Maximum recommended steel thickness: 2.0 mm 	\$ 69,000.00 + GST

uPVC Glazing Bead Saws

For automatic cutting of 45 degree glazing beads for uPVC windows. With option manual, digital measuring or wireless transfer from electric measuring calliper.



Part Number	Equipment Description	Price Ex GST
CK412	2 x 200mm & 2 x 110mm blades, 2 x 1.2kW motor, standard 1.5 Metre manual stop. Optional 3.0 Metre. 8 Position stopper.	\$ 5,990.00 + GST
CK412 + SKN301	2 x 200mm & 2 x 110mm blades, 2 x 1.2kW motor, 3.0 digital stop. Optional Wireless measuring devices 1.5 & 3.0 Metres	P.O.A

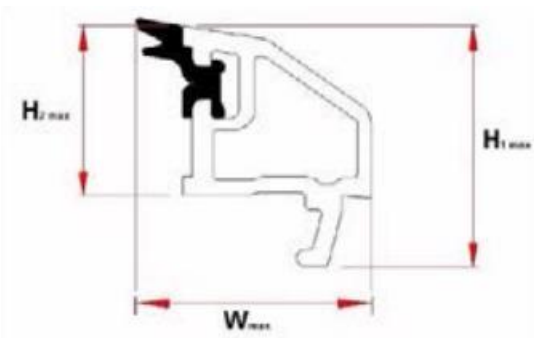



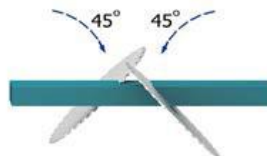



Wmax: 40 MM
W min : 10 mm
H1-H2: 6 MM
H2max: 30 MM
H1max: 36 MM
KONVEYOR ÖLÇÜ CETVELİ 1500 MM

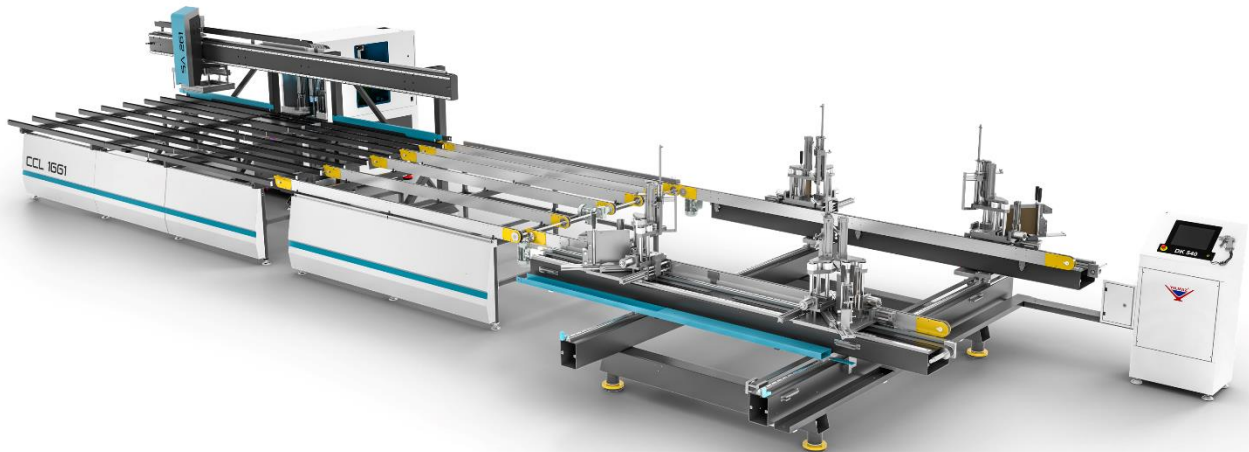

uPVC Processing Line

CCL 1661 - CNC controlled four corner uPVC welding and cleaning line. After welding process on the DK 540, the frame goes to the Cooling Unit (SA 250) automatically. Then the Robot Unit (SA 260) automatically takes the frames from the Cooling Unit (SA 250) where the cleaning process starts and carries it by turning to the CNC 608 (2 Servo unit) or 610 (4 Servo unit) Cleaning Machine.



Part Number	Component Description
 <p>DK 540</p>	<p>Four Head Welder</p> <ul style="list-style-type: none"> • 180mm weld height • 0.2mm – 2.0mm Weld • 90 Degree • Min 400mm, Max 2700x3100mm frame <p>Adjustable melting and welding time</p>
 <p>CS 240</p>	<p>Gasket Pressing System</p> <ul style="list-style-type: none"> • Option for DK 540
 <p>SA 250</p>	<p>Cooling Unit</p> <ul style="list-style-type: none"> • Option for DK 540 • 2000mm x 3000mm
 <p>SA 260</p>	<p>Rotating table for CNC 608 and CNC 610</p>
 <p>CNC 608</p>	<p>90 degree weld cleaning, up to 180mm high, 2 Axis/Servo Motors CNC 6500 profile memory. Process 210-230 window frames in 8 hours</p>
 <p>CNC 610</p>	<p>90 degree weld cleaning, up to 180mm high, 4 Axis/Servo motors CNC. Independent controller for the top and bottom cleaning knives. 6500 profile memory Process 260-280 window frames in 8 hours</p>